

**INSTALLATION INSTRUCTIONS
&
USER MANUAL**

AVD-300

Outdoor Double Optics PIR + MW detector with Pet immune

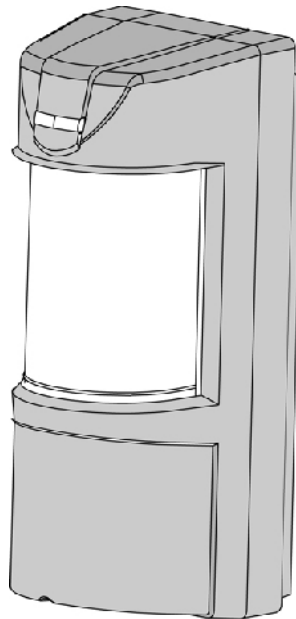

Item AVD-300 English, Version 5, October 2013



Index

| | | |
|-----|--|----|
| 1 | General | 3 |
| 2 | Features | 3 |
| 3 | Assembly description | 4 |
| 4 | Detection Pattern | 5 |
| 5 | Selecting mounting location | 6 |
| 6 | Detector Installation | 7 |
| 7 | Terminal Block Connections | 9 |
| 7.1 | Wire Size Requirements | 9 |
| 8 | Settings & Adjustments | 10 |
| 8.1 | Detection beam direction | 10 |
| 8.2 | Detection range setting | 10 |
| 8.3 | Sensitivity, Range and Pet immune Adjustment | 11 |
| 8.4 | Indications setting | 12 |
| 9 | Operation | 13 |
| 10 | Test Procedure | 13 |
| 11 | Specifications | 14 |

1 **General**

The AVD-300 is unique Passive Infra-Red and Microwave detector for outdoor and harsh environment applications.

The AVD-300 is designed for outdoor usage in most severe and extreme acclimate conditions that may also accommodate pets.

High reliability is achieved by combining both dual tech hardware with highly sophisticated software as well as an adaptive coverage area, reducing false alarms alerts to zero.

It comprises of Double Optics and advanced MW Detector inside stylist rigid plastic body.

This special optics combined with state of the art MW Doppler sensor assures elimination of “false alarms” while maintaining high security standards for the detection of human intruders into protected area.

The detection sensitivity and range is controlled by digital rotary switch allowing 16 calibration levels, so that the effective pattern will be set for every installation environment and protection site.

The AVD-300 is designed to protect large areas and can easily be installed on walls in order to provide a solid protection of the area while rejects interferences from birds and small animals due to “PET MASK” optics.

2 **Features**

- MW detection based on Doppler concept.
- N.O. & N. C. Relays switched at the same time.
- Height installation calibrations free, from 2.6 ft (0.8m) to 4.9 ft (1.5m)
- Selectable pet immunity between 44 lbs (20kg) and 77 lbs (35kg).
- 16 levels of PIR sensitivity adjustment including 3 MW sensitivity groups.
- Temperature compensation.
- Micro controller signal processing.
- Front and back tamper protection.
- Sound indication for walk test and intruder detection.
- Unique waterproof and seal plastic design.
- Detection Range: Up to 49 ft (15m) at 20°C, up to 11m at 25-30°C
- Detect human intruders walking or running.
- No maintenance required.
- High RFI/EMI Immunity.
- Protection from: direct sunlight, wind up to 30m/sec, snow and rain, small animals, removing the top cover, housing pulling out or destruction

3 Assembly description

The AVD-300 is a robust detector which includes large indication LED prism that can be easily observed from long distance. Having a back metal bracket, the AVD-300 can be easily mounted to walls and poles using mounting screws or metal bands (supplied).

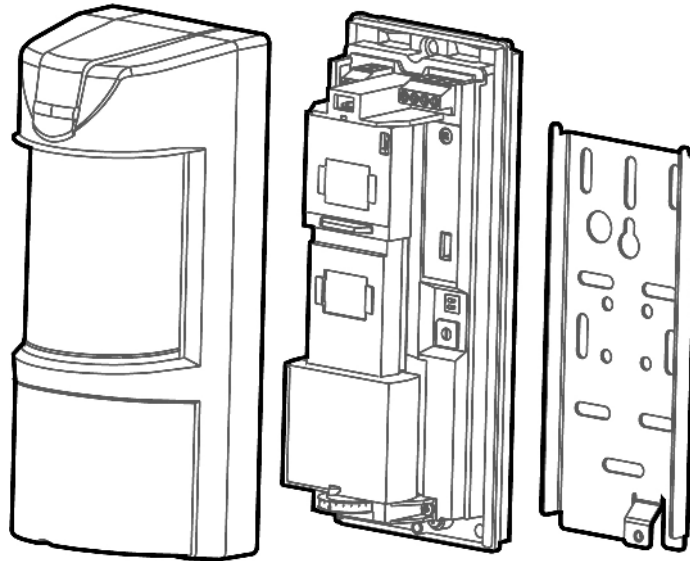

The AVD-300 is combined of three detection elements:

Upper PIR element

Lower PIR element

Microwave element

The upper PIR element has an adjustable detection height while the other two are fixed.

The following drawing shows all internal elements:

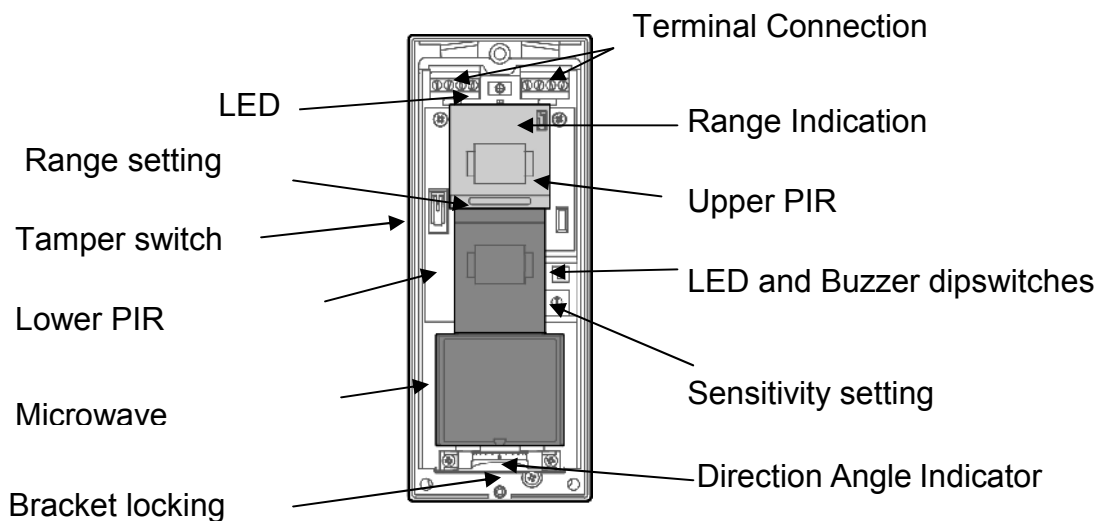

4 Detection Pattern

The AVD-300 has a 90° top view PIR and MW detection pattern with over 49 ft (15m) detection distance (when installed at 4 ft (1.2m) above the ground surface).

The AVD-300 has an internal rotating housing (which includes the 2 PIR elements and the MW) that can be adjusted horizontally, so its 90° coverage may vary between 0° and 180°.

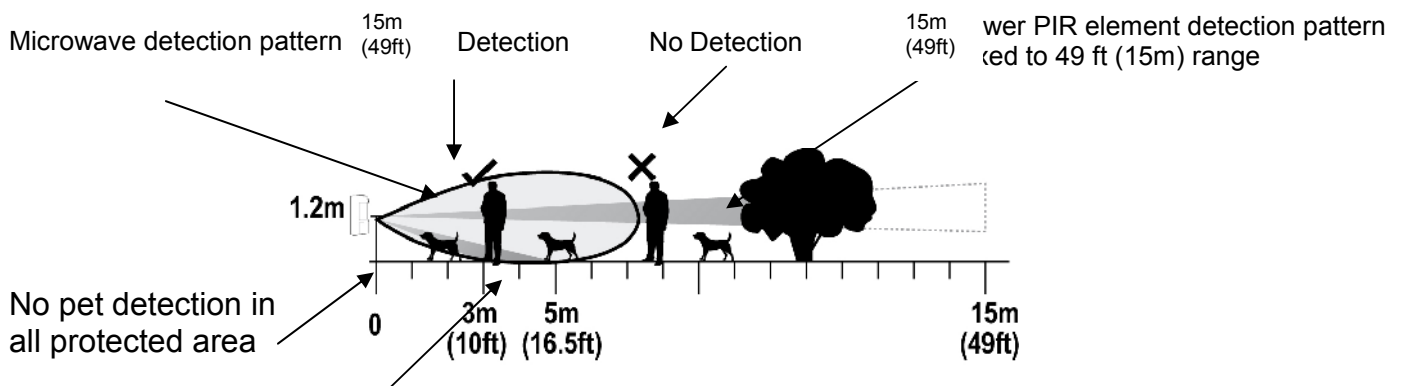
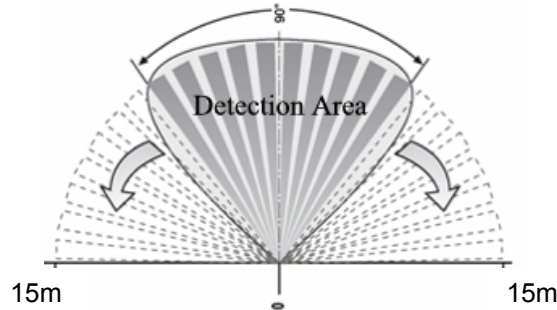

Upper PIR element detection pattern
Adjustable between 10 ft to 49 ft (3m to 15m)

Consider the effective range as 10-12 meters when temperature is over +20°C.

The AVD-300 can differentiate between pets and human bodies and alert accordingly by having MW movement detection combined with two PIR detection beams:

- A. Lower PIR element which is fixed to 49 ft (15m) range and 2 ft (60cm) above ground level which helps avoiding pets detection over the entire area.
- B. Upper PIR element which has adaptive range between 10 ft (3m) and 49 ft (15m).

By having both PIR detection beams and MW detection the crossing object will be defined as intrusion, causing an alarm.

In case of MW detection with only one of the beams no alarm will be generated.

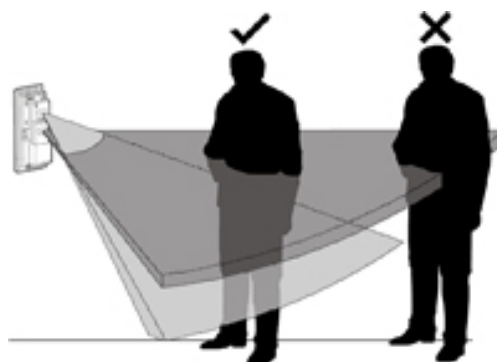

5 **Selecting mounting location**

The installation of the AVD-300 requires straight and solid base for the detector and setting of front panel against the center of protected area.

The protected area must be free from obstacles like walls, fences, trees, ditches and other microwave detectors, as well as systems of anti-intrusion surveillance.

The bracket provides AVD-300 installation on a wall or pole. The wall or pole should be leveled. Choose a location most likely to intercept an intruder according to detection pattern on page 6.

Avoid the following Installation Locations:

- Facing direct sunlight.
- Facing areas subject to rapid temperature changes.
- Wall angle of more than 10° from perpendicular line.
- Mounting at more than 10° Deviation from horizontal line.
- Facing metal doors.
- Do not install near direct source of heat or air gust.
- Clear all physical obstacles from the detection area (e.g. Plants, laundries, etc.)
- Clear all light reflecting surfaces from the detection area, as well as water puddles.
- Avoid installation on the following types of ground:
 - Thick vegetation, short grass (un-mown), water, sand and metal

Note:

Recommended installation height is 4 ft (1.2m).

Notice: If there is a risk of tall pets (over 2 ft / 60cm) the detector is to be installed at 4.5 ft (1.4m).

The Double Dual high quality sensor detects motion crossing the beam; it is less sensitive detecting motion towards the detector.

The AVD-300 performs best when provided with a constant and stable environment.

In order to ensure suitable operation of the AVD-300 type of ground should be one of the following: Asphalt concrete, Cement, Soil, Clay, Gravel or Grass (mown).

6 Detector Installation

Important! Prior to installation, read both “Operation” and “Selecting the mounting location” sections carefully.

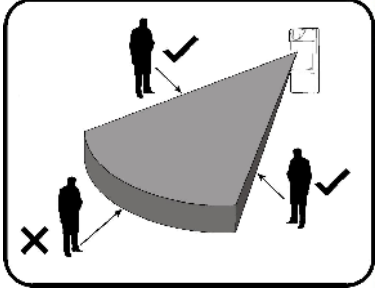
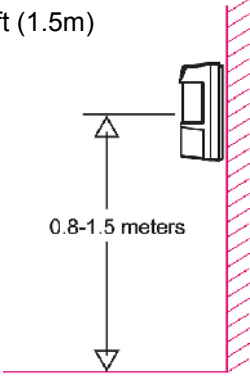
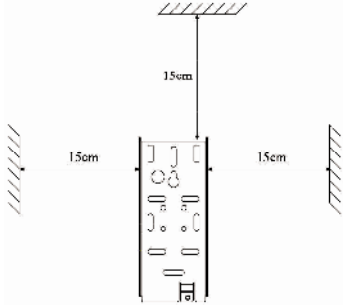
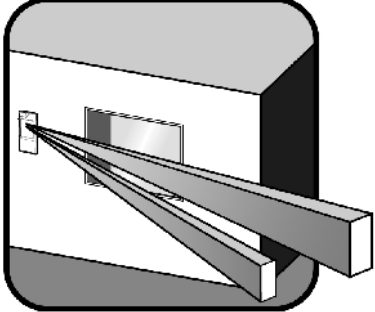
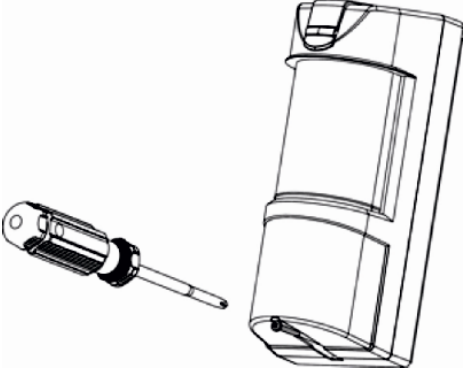
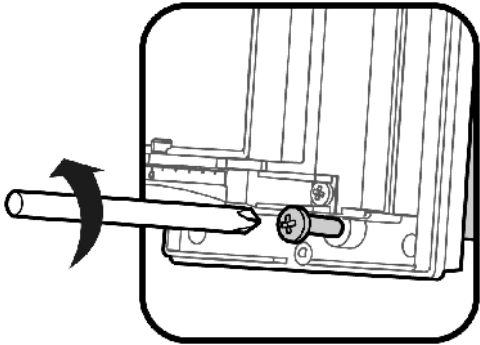
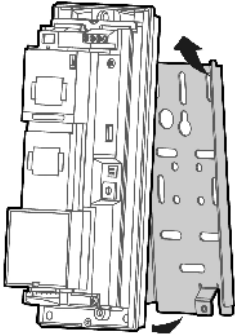
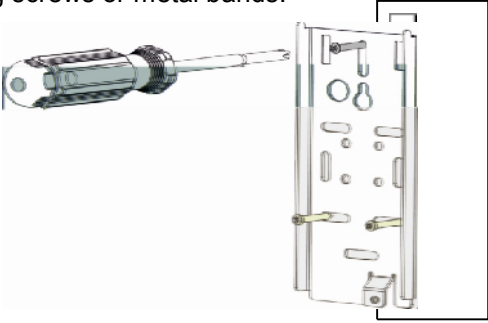
| | |
|--|--|
| <p>1. Install the detector in such manner that the intruder is most likely to cross the detection area from side to side.</p>  | <p>2. The detector is to be installed at height of 2.6 ft (0.8m) to 4.9 ft (1.5m)</p>  |
| <p>3. Make sure to attach the metal bracket to a leveled straight and firm wall, leaving 6 inches (15cm) from the top and 6 inches (15cm) from both sides, for easy installation and maintenance.</p>  | <p>4. Rotating the detection beam may be required for guarding a side window opening while the detector is installed facing another direction.</p>  |
| <p>5. Open the detector unwinding the bottom screw.</p>  | <p>6. Release the rear metal bracket by unwinding internal bottom screw.</p>  |
| <p>7. Release the detector body from the metal bracket by polling front and up.</p>  | <p>8. Attach the rear bracket to the wall or a pole using mounting screws or metal bands.</p>  |

9. Break the relevant rear knockouts on plastic base rear side for your installation and slide the wires from the outside via the paths and knockout to the internal side of the detector.

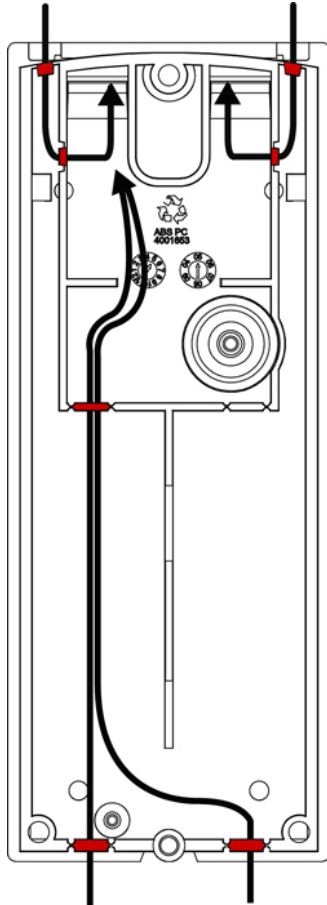

10. Attach the sealing "U" shaped Sponge Pad to the wire opening from the rear side after the wires connection and prior to final product affixing to the mounted bracket.

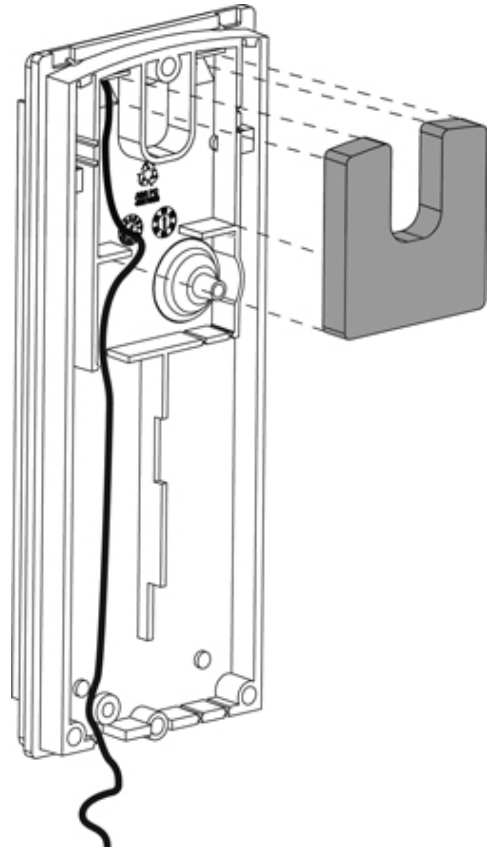

11. Place the detector on the mounting bracket from top side down and then lock the screw at the bottom.

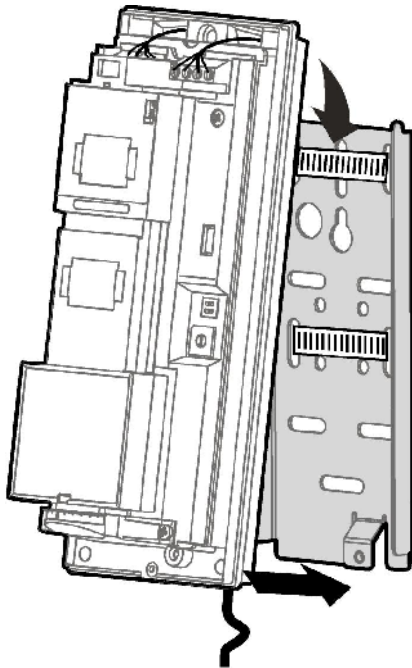

12. Connect the wires to the terminal blocks according to the following chapter.

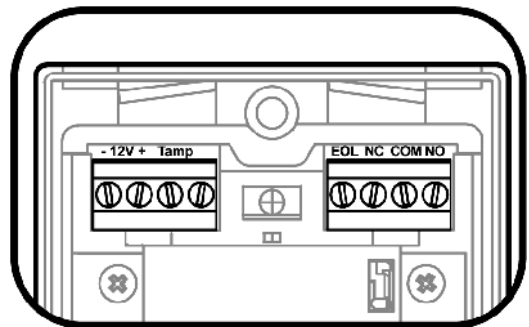

7 Terminal Block Connections

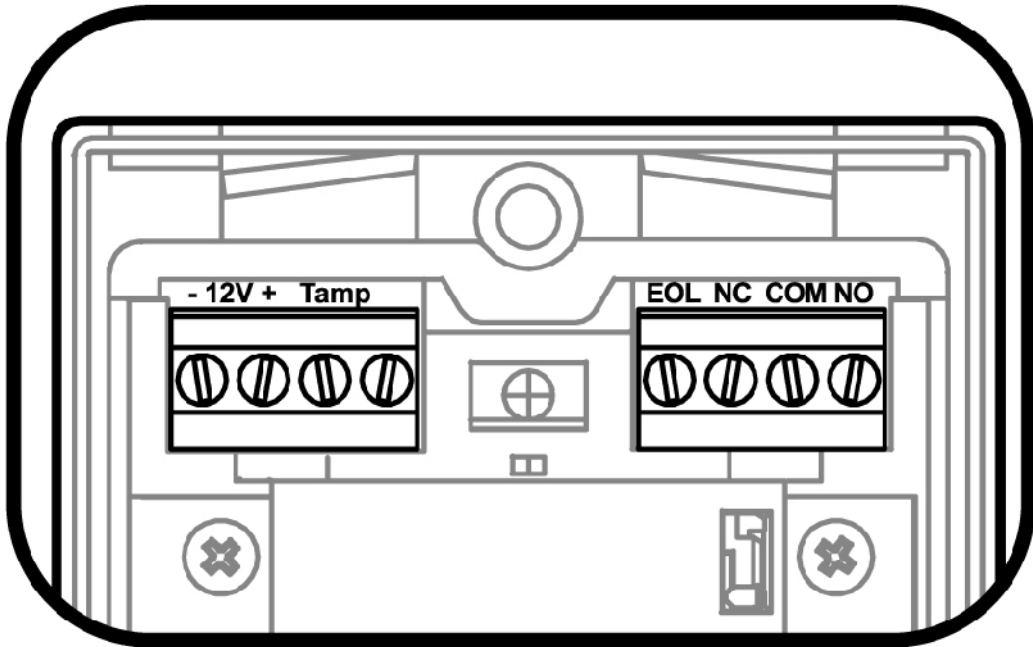

Terminal 1 - Marked “-” (GND) - Connect to the ground of the CP (control panel).

Terminal 2 - Marked “+” (+12V) - Connect to a positive Voltage of 9.6 -16Vdc source (usually from the alarm CP)

Terminals 3 & 4 - Marked “TAMP” - If a Tamper function is required connect these Terminals to a 24-hour normally closed protective zone in the CP.

If the top cover of the detector is opened or the detector is detached from installation wall, an immediate alarm signal will be sent to the CP.

Terminal 5 - Marked “EOL” - End of line – Optional terminal for end of line resistors connections.

Terminals 6, 7 & 8 - Marked “NC / C / NO” - These are the output relay contacts of the detector. Connect to a normally closed or normally opened zone in the control unit. When an intruder is detected, alarm relays (N.C. and N.O.) will switch for 1.8 sec.

7.1 Wire Size Requirements

Use #22 AWG or larger wires. Use the following table to determine required wire gauge and length.

| | | | | |
|-------------------|-----|------|------|------|
| Wire Length [m] | 205 | 310 | 510 | 870 |
| Wire Length [ft.] | 800 | 1200 | 2000 | 3400 |
| Wire Gauge [#] | 22 | 20 | 18 | 16 |

8 Settings & Adjustments

8.1 Detection beam direction

The AVD-300 detection beam direction may vary between 0° and 180°.

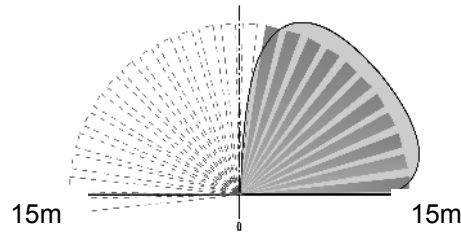

In order to change the detection beam direction rotate the internal detection element housing to the desired direction.

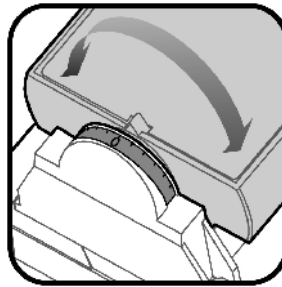

8.2 Detection range setting

The AVD-300 detection range may vary between 10 ft (3m) and 49 ft (15m), while installed on 4 ft (1.2m) height above the ground surface.

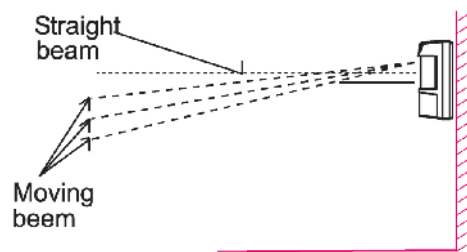

Changing the detection range is achieved by sliding the upper detection element up or down. Slide the detection element down for long range or up for short range detection.

See the drawing below.

At "0" is highest sensitivity, "F" the lowest

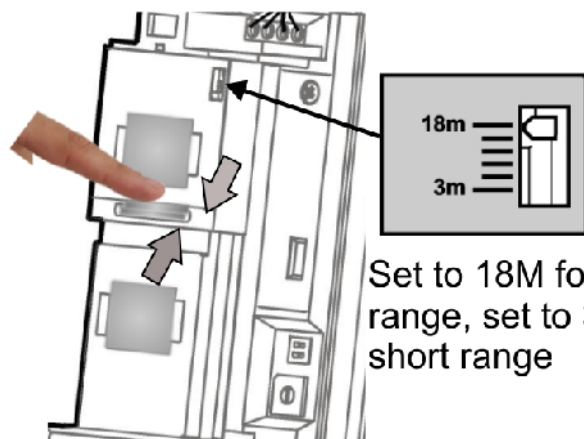
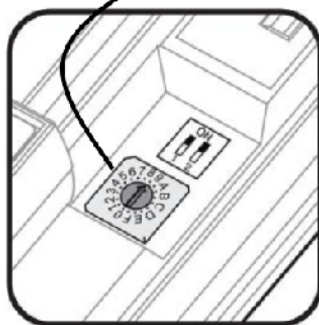

Set to 18M for long range, set to 3m for short range

8.3 Sensitivity, Range and Pet immune Adjustment

The calibration of range and sensitivity is performed by single digital 16 position rotary switch. There are 3 groups of switch setting according to detection range.

Each group is divided to several levels of sensitivity according to installation environment.

The sensitivity is determined by a rotating switch (16 positions). Changing the sensitivity affects immunity to environmental noises, also affects the detection distance and pet immunity level.

The rotating switch is marked with digits from “0” to “9” and following letters from “A” to “F”.

Position “0” is maximum sensitivity and “F” is minimum sensitivity.

Note: Adjust sensitivity according to environmental conditions!

Group A - positions 0 – 7 – set sensitivity for 49 ft (15m) detection range with immunity to pets weight up to 33 lbs (15kg) – very sensitive – 1 pulse.

Group B - positions 8 – A – set sensitivity for 31 ft (10m) detection range with immunity to pets weight up to 44 lbs (20kg) – less sensitive – 2 pulses.

Group C - positions B – F – set sensitivity for 16 ft (5m) detection range with immunity to pets weight up to 77 lbs (35kg) – less sensitive – 2 pulses.

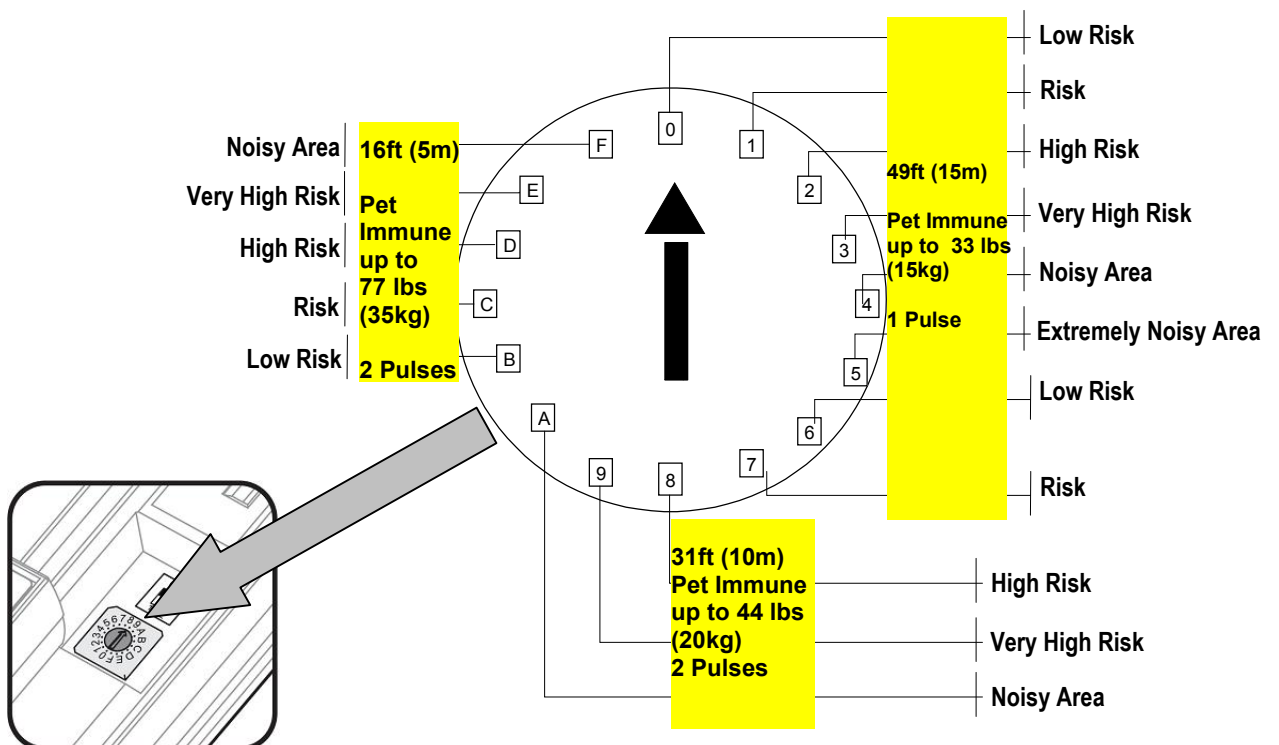

Each group is divided to 5 or 6 sub-positions that help to define the environmental condition inside the detection range:

- Low risk: very stable environment without interference like parking garage, under roof parking space, playground, football court, service road, etc.
- Risk: Stable environment with some trees, bushes, flowerpots, planters.

- High risk: Unstable environment with different types of vegetation and grass and puddles.
- Very high risk: Unstable environment with winds and small pets, rats, mice, birds.
- Noisy area: Unstable environment with vegetation and water sources like swimming pool, lake, canal, weed as well as small pets like cats and rabbits.
- Extremely Noisy area: Very unstable environment subjected to wind, snow, rain, with vegetation, water and large pets like dogs.

For example:

If detector is used for 13m range in open space with sunlight and pets, set switch to position 9.

For range testing set switch to "0" (zero), keep installation height at 0.9m maximum.

8.4 Indications setting

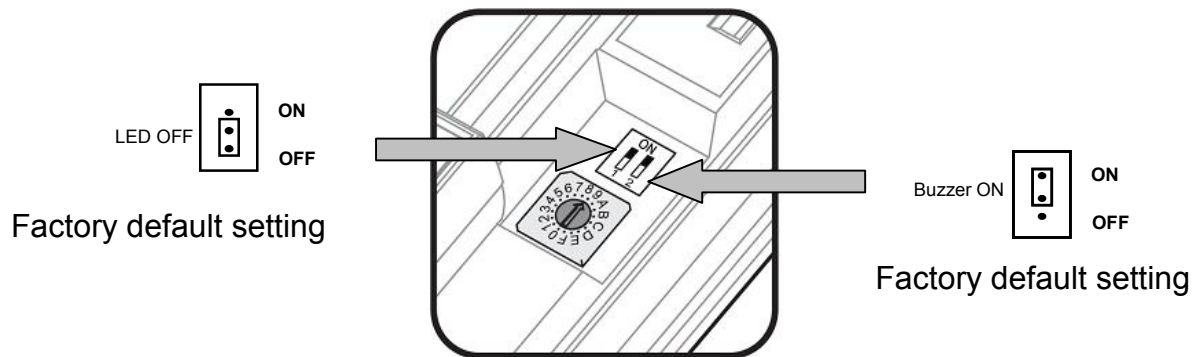

The AVD-300 has two types of indications:

1. LED
2. Buzzer

The installer may determine both indications' operation during detection (ON or OFF) by using switch number "1" for the buzzer and switch number "2" for the LED.

(Setting the buzzer ON gives the installer the ability to hear the beep on each detection for 1.8 seconds during the adjustments and a walk test. After the process it is recommended to switch the buzzer OFF).

- Place the top cover to the base and close it using the bottom screw.

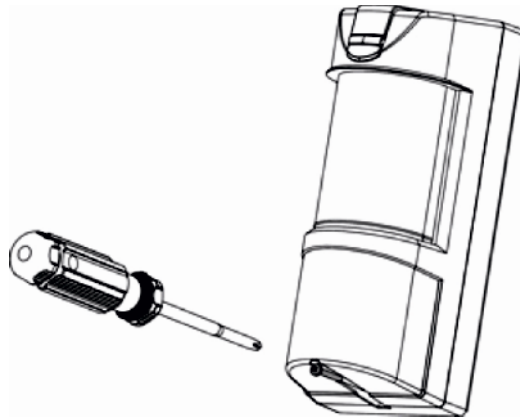

9 Operation

Connect the AVD-300 to a positive Voltage output of 9.6 -16VDC source.

Use only a listed power limited source.

Provide minimum of 4 hours of standby power from either a listed compatible control unit or power supply.

The detector is automatically operated once connected to power.

The LED starts flashing for 30 seconds during the setup period and after that it will turn off.

At this time the detector is ready for operation.

10 Test Procedure

Walk Test

Allow 2 minutes of warm up time.

Make sure that the protected area is cleared of all people.

Start walking across the detection zone.

Listen to ALARM sound whenever motion is detected (the red LED also turns ON whenever motion is detected).

Allow 5 sec. between each test for the detector to stabilize.

Upon installation, the unit should be thoroughly tested to verify proper operation.

Walk across the entire area where coverage is desired. Should the coverage be incomplete, readjust coverage range or relocate the detector.

Once coverage is as desired, the alarm buzzer should be disabled and the LED may be disabled.

Important:

Make walk test at least once a week, to confirm proper operation, alarm trig and coverage of the detector.

11 Specifications

| | |
|---|--|
| Detection Method | Double Dual Element PIR & MW |
| Microwave Frequency | 24.125 GHz |
| Power Input | 9.6 to 16Vdc |
| Current Draw | Active: 24mA (±5%) Standby: 21mA (±5%) |
| Temp Compensation | Dual slop temperature compensation |
| Alarm Period | 2 sec (±0.5sec) |
| Alarm Outputs | Form C (NC, NO, Common). 28Vdc 0.1 A with 10 Ohm |
| Tamper Switch(s) | Two Switches N.C 28Vdc 0.1A with 10 Ohm Series protection resistors Opens when cover is removed from unit's base |
| Warm up Period | 120sec (± 5sec) |
| LED Indicator | LED is ON during ALARM |
| RF Immunity | 10 V/m plus 80% AM from 80 MHz to 2GHz |
| Electro Static Immunity | 6kV contact, 8kV air |
| Transient Immunity | 1kV |
| Operation Temp | -35°C ~ +55°C (-31°F ~ 131°F) |
| Dimensions | 7.9" x 3.4" x 3.2" (200mm x 86mm x 80mm) |
| Weight | 1100 lbs. (500gr.) |
| European directives | RTTE directive: 1999/5/EC EMC directive: 89/336/EEC Low Voltage directive: 73/23/EEC RoHS directive: 2002/95/EC |
| European standards requirements: | EN300 440-2 EN301 489-1 EN50130-4 +A1 +A2 EN61000-6-3+A11 EN60950-1 EN50131-1 / EN50131-2-4 / EN50130-5 |
| USA & Canada | 47CFR part 15, subpart C, section 15.245 47CFR part 15, subpart, RSS210, ICES-003 |
| Protection Degree | IEC 60529: IP 65 |

* Specifications are subject to change without prior notice.

www.av-gad.com

NOTE: Conduct Walk Test procedure at least once a week, to confirm proper operation and coverage of the detector. Consider sensitivity reduction at over 35° Celsius environment

Limited Warranty

Av-Gad Systems Ltd. and its subsidiaries and affiliates (“Seller”) warrant its products to be free from defects in materials and workmanship under normal use for 12 months from the date of sale. Because Seller does not install or connect the product and because the product may be used in conjunction with products not manufactured by Seller, Seller cannot guarantee the performance of the security system which uses this product. Seller’s obligation and liability under this warranty is expressly limited to repairing or replacing, at Seller’s option, within a reasonable time after the date of delivery, any product not meeting the specifications.

Seller makes no other warranty, expressed or implied, and makes no warranty of merchantability or of fitness for any particular purpose.

In no case shall seller be liable for any consequential or incidental damages for breach of this or any other warranty, expressed or implied, or upon any other basis of liability whatsoever.

Seller’s obligation under this warranty shall not include any transportation charges or costs of installation or any liability for direct, indirect or consequential damages or delay.

Seller does not represent that its products may not be compromised or circumvented; that the product will prevent any personal injury or property loss by burglary, robbery, fire or otherwise; or that the product will in all cases provide adequate warning or protection.

Av-Gad Systems Ltd. and its subsidiaries and affiliates (“Seller”) warrant its products to be free from defects in materials and workmanship under normal use for 12 months from the date of sale. Because Seller does not install or connect the product and because the product may be used in conjunction with products not manufactured by Seller, Seller cannot guarantee the performance of the security system which uses this product. Seller’s obligation and liability under this warranty is expressly limited to repairing or replacing, at Seller’s option, within a reasonable time after the date of delivery, any product not meeting the specifications.

Seller makes no other warranty, expressed or implied, and makes no warranty of merchantability or of fitness for any particular purpose.

In no case shall seller be liable for any consequential or incidental damages for breach of this or any other warranty, expressed or implied, or upon any other basis of liability whatsoever.

Seller’s obligation under this warranty shall not include any transportation charges or costs of installation or any liability for direct, indirect or consequential damages or delay.

Seller does not represent that its products may not be compromised or circumvented; that the product will prevent any personal injury or property loss by burglary, robbery, fire or otherwise; or that the product will in all cases provide adequate warning or protection