

EasyLoader

AV-2016D, AV-2016DP

AV-2055D, AV-2088D

(for LED keypad)

Integrated Alarm Control/Communicator

Installation and Operation Manual

Version 3.05D

Edition II

This product is subject to continuous enhancements and therefore specifications may be changed or altered without prior notice

Item: 4712_BIG (A4BKE)



Av-Gad Systems Ltd. Panorama House
84, Ben Zvi Road, Tel-Aviv 68 104, Israel
P.O.B. 49 080, Tel-Aviv 61 490, Israel
www.av-gad.com
Tel: 972-3-681 6767. Fax: 972-3-683 5505

Table of Contents

<i>Contents</i>	<i>Page</i>
SECTION I: SYSTEM FEATURES	4
1. INTRODUCTION.....	4
1.1 <input type="checkbox"/> General Description.....	4
1.3 <input type="checkbox"/> Programmable Features	5
1.4 <input type="checkbox"/> Alarm and Power Outputs	5
1.5 <input type="checkbox"/> Ordering Information.....	7
1.6 <input type="checkbox"/> AV-2016D, AV-2055D, AV-2088D Technical Specifications.....	8
SECTION II: INSTALLATION.....	10
2. MOUNTING	10
2.1 <input type="checkbox"/> Control Panel Mounting	10
2.2 <input type="checkbox"/> Connection of AV-816 Expander.....	12
2.3 <input type="checkbox"/> AV-2055, 2088D Wiring.....	13
2.4 <input type="checkbox"/> Keypad Wiring	14
3. ALARM OUTPUTS	16
3.1 <input type="checkbox"/> Sirens.....	16
3.2 <input type="checkbox"/> Remote Indication Terminals	16
3.3 <input type="checkbox"/> Wiring and Connection of Relay Module.....	17
4. WIRING AND POWERING UP	18
4.1 <input type="checkbox"/> Grounding – Lightning Protection.....	18
4.2 <input type="checkbox"/> Back-up Battery.....	18
4.3 <input type="checkbox"/> Before Powering Up.....	18
4.4 <input type="checkbox"/> Connecting Smoke Detectors	19
4.5 <input type="checkbox"/> Telephone System Dialing.....	20
4.6 <input type="checkbox"/> SVM – Voice module.....	20
4.7 <input type="checkbox"/> Remote Key and Wireless Arming & Disarming.....	21
4.8 <input type="checkbox"/> Remote Access via DTMF	21
SECTION III: AV-701 & AV-702 DIGITAL KEYPAD.....	23
1.1 <input type="checkbox"/> Standard Keypad Functions.....	23
1.2 <input type="checkbox"/> Hold-Down Functions	25
1.3 <input type="checkbox"/> Keypad Sounder	29
1.4 <input type="checkbox"/> LED Indicators	30
1.5 <input type="checkbox"/> Keypad Digital Display (7-segment type)	31
1.6 <input type="checkbox"/> Arm and Disarm System via AV-701/702 Series Keypad	32

SECTION IV: PROGRAMMING	34
1. SYSTEM CODES	34
1.1 <input type="checkbox"/> User Code Programming via AV-701 Keypad (Not with AV-2016DP)	35
2. FEATURE PROGRAMMING AT INSTALLER LEVEL	36
2.1 <input type="checkbox"/> Programming Table AV-20055D, 2088D, 2016D, 2016DP (V3.05).....	36
2.2 <input type="checkbox"/> Introduction	44
2.3 <input type="checkbox"/> Programming Sheet Explanation.....	44
2.4 <input type="checkbox"/> Glossary of Programmable Features.....	46
2.7 <input type="checkbox"/> Step - By - Step Programming.....	51
2.8 <input type="checkbox"/> Reset System to Default Programming	55
2.9 <input type="checkbox"/> Dialer- Communicator; explanation and Programming	55
2.9.1 <input type="checkbox"/> Deleting Telephone Numbers	56
2.9.2 <input type="checkbox"/> User Programming of 'Follow-Me' Telephone Number	57
2.10 <input type="checkbox"/> Quitting Programming Mode.....	57
2.11 <input type="checkbox"/> Verification of Current Programming.....	57
2.12 <input type="checkbox"/> Downloading from a computer	57
3. PARTITIONED SYSTEM – TYPE AV-2016DP.....	63
3.1 <input type="checkbox"/> Partition Definition	63
3.2 <input type="checkbox"/> AV-2016DP - Users Options	64
3.3 <input type="checkbox"/> AV-2016DP - Keypad Operation.....	64
3.4 <input type="checkbox"/> AV-2016DP - 'Hold Down' Keypad Functions	66
3.5 <input type="checkbox"/> AV-2016DP LED Indicators.....	68
3.6 <input type="checkbox"/> System Codes.....	68
4. TROUBLESHOOTING	69
SECTION V: WIRING DIAGRAM	73
SECTION VI: INDEX.....	74
Av-Gad Limited Warranty.....	76

SECTION I: SYSTEM FEATURES

1. INTRODUCTION

1.1 □ General Description

- *Av-Gad's EasyLoader™ AV-2055D, AV-20088D, AV-2016D, AV-2016DP* are microprocessor based intruder alarm panels with integrated communicator. They feature 5, 8, 16 or 32 double-zone all of them are expandable and compatible to Av-Gad LED keypads. Series 2000 represents the state-of-the-art in user-friendly, reliable alarm control panels for security requirements of small and medium-size commercial, residential, and industrial installations.
- *Av-Gad's EasyLoader™ AV-2016 and AV-2008* versatile control panels meets, surpasses all requirements for reliability and maintainability, and provides the added benefits of easy installation and simple operation.
- The *Dublo Version* is an upgraded model of the *AV-2016*, designed to be compatible with AV-705, 706, 707 and AV-707B LCD (English Text) keypads. Refer the AV-2016 Dublo manual.
- *The AV-2016* comprises an enhanced power supply, improved electronics, and additional signaling indicators.
- *The 2000 Series* innovative keypads (AV-701 & AV-702) are unquestionably the most user-friendly remote station, designed to enable control of the system by the end-user, as well as by the installer.

Version 3.00 news

➤ Version 3.00: The Spare output (2016) terminal removed, DTMF control (arm, disarm, etc) is standard, panel version identifies itself as AV-2016D (EasyLoad software), self test at initialization (STI) - Dial LED blinks for the first 50 seconds after power on, new factory defaults, address 052: Set the signal test per days, improved lighting protection with option for heavy duty lighting protection, CS testing day programming. Home Automation: Activation of A1 and SLO outputs via DTMF, First alarm indication reported via DTMF.

Version 3.04: New at 072-4, activate ON output to drive ADSL filter line disconnect, added 999 to exit programming mode, during Answer Now mode keypad display CA, improved Contact ID format. New AV-2016 box is ready for extra AV-21 power supply and 5003TER transformer. **Version 3.05:** Enable Last Zone as Aux. Key, including AV-2055D, AV-2088D. **Version 3.05A:** Code 8 problem fixed. **Version 3.05C:** Siren wiring in case of troubles, see section 3.1.

1.2 Built-in Features

- Accepts Normally Closed or Normally Open alarm devices
- All features are programmable via system keypad
- Automatic battery test upon arming and during Disarmed or Armed mode
- True low battery indication
- Central station communicator and dialer. Communicator is compatible with most major formats: Ademco Slow and Express, Radionics, Scantronic, SESCOA, Contact ID, etc
- Chime programmable for each zone
- Digital zone status display
- Double-Pole zones. Tampering indication for each zone
- Eight partitions with the AV-2016DP, compatible with LED keypads only
- Keypad sounder during local alarm
- Local clock and date
- Modulated tone siren from 24H and panic zone(s), 3-tone alarm from burglary zones
- Programmable four or five output drivers for remote signaling and reset of smoke detectors
- Programmable 16 or 32 EOL resistor zones, or non-EOL zones
- Pulse-operated battery charging circuit
- Two dialing modes: Pulse or DTMF. Dialing to pagers in Hong-Kong and Singapore
- Signals to central station monitoring (via wire or wireless)
- Up and Download from a computer, or via telephone line
- Up to 250 alarm logs, with event time
- Up to 8 or 16 user codes, each code one to six digits. One installer code, access control code
- Up to 32 (2016) EOL supervised double-zone. One Panic zone at keypad

1.3 Programmable Features

- Thirty-two End-Of-Line zones (with AV-816), EOL zone enable or disable
- Individual entry delays for two zone groups.
- Automatic bypass of open (troubled) 'instant' zones upon arming
- Selective and Zone Group Bypass (Group Shunt for Home Mode)
- 24-hour zones, fire zone
- Zone types: Delayed, Follower, Fire, Not in use, Day, Tamper, Panic zone and more
- Selectable response time for individual zones

1.4 Alarm and Power Outputs

- Five programmable open collector output drivers for remote alarm signaling
- Contains auxiliary output for electric strike operation
- Communicator to central station and alarm sound dialer
- Keypad sounder alarm programmable by zone
- Two timed siren outputs, protected by separate fuses
- Variable sirens alarm sound for different types of zones
- Two separate fused protected auxiliary power (12V) outputs

- Signal test to central station, signaling time and day are programmable
- Programmable 'Bell Mode'
- SPR output toggle mode via hold down key
- Remote Signals:
 - 24H-zone Alarm
 - On/Off (Arming/Disarming) indication
 - Central station Signal Test. Transmitting time is programmable
 - Panic, Tamper alarm
 - Programmable output for each zone or event (SLO output)

1.5 □ Ordering Information

Item Code	Description
AV-2016D AV-2016D4F	16 + 1 double-zone Alarm Control Panel and Communicator/Dialer. Supports AV-701, AV-702 keypad. Approved for EEC telephone (“E” mean CTR-21 compatible). AV-2016D4F with four outputs controlled by DTMF for remote appliances activation
AV-816	16 zone expanding module compatible with AV-2016
AV-208	8 zone expanding module compatible with AV-2055, 2088D
AV-2016DP	16 + 1 zone Alarm Control Panel and Communicator / Dialer, with eight partitioned. Supports AV-701, AV-702
2055_4PCB	Board only for AV-2055D (5 or 10 zone expandable to 26)
2088_4PCB	Board only for AV-2088D (8 or 16 zone expandable to 32)
2016P_4PCB	Board only for AV-2016DP
2016_4PCB	Board only for AV-2016D
TMP	Tamper switch with wires for main alarm metal box. Not supplied, requires special order
AV-701TS	4-wire Keypad. 7-segment Digital Display, 4 LEDs, 12 silicon rubber keys, semi-back light, local sounder. Connected to panel via 4 terminal wires. Compatible with AV-2016D, AV-2016DP
AV-701TI AV-701TP	Identical to AV-701TS, with additional timed backlight illumination. AV-701TP includes Tamper protection
5003TER	Fuse-protected 220V step-down to 16V-1.2A AC transformer for AV-2055, 2088D Series
5005TER	Fuse-protected 220V step-down to 16V-1.7A AC transformer for AV-2016 Series
AV-702 and AV-702TP (Tamper added)	New shape housing. Improved circuitry provides longer wiring and better communication. 4-wire Keypad. 7-segment Digital Display, 4 LEDs, 12 silicon rubber keys with protection door, local sounder
RELAYMO	Relay module for driving self-powered siren in Series 2000. (Used in France, Italy, UK and other countries.)
SVM-40/60	Speech module, record & play, message stored without power, 40 or 60 seconds message. Two channels. For message recording an on-board microphone is included
AV-21, AV-21B and AV-40	Extra 12V-1A or 4A, power supply and charger, supplying the power for large installations. AV-21 supplied as PCB. With AV-21B the PCB housed in box. AV-40 is 4A type

1.6 □ AV-2016D, AV-2055D, AV-2088D Technical Specifications

Operating Temperature	-10°C to 60°C
Relative Humidity	80% maximum
Input AC Power	16V AC step-down Transformer 1.7 Amp
Dynamic Inner Memory	EPROM and SRAM
Auxiliary Power Output	13.8 Volts +/- 5%, Regulated Short & Overload circuit protection
Siren Outputs (x2)	Siren or Bell Selectable Bell Mode: 14V DC-2 x 0.7A (1.4A) Siren: 8 Ohms, 20W Max.
Programmable Dialer: 3 telephone numbers & 1 Follow Me telephone number (4 phone numbers) Multi-format central-station communicator	Pulse Dialing parameters programmable DTMF: Touch Tone dialing ® Max. Telephone number length: 16 digits and 4 pauses
Remote Indications on Wire Terminal	Open Collector type output 300 mA Max. @ 12V DC
EOL Zone Loop Resistor (Burglary)	2,200 Ohms, 0.25W, +/- 5%
EOL Zone Loop Resistor (Tamper)	4,700 Ohms, 0.25W, +/- 5%
Zone Loop Voltage	5 to 6.5V DC
Zone Loop Current	3 mA with End-Of-Line Resistor
Line Protection	Zone line shorting, cutting, high voltage lightning protection, RF Metal Screen, Electro Static Discharge Traps, RF Filters. Telephone line Lighting protection circuit
Auxiliary Power (Max.)	13.8V DC 1.4A Combined AUX. Power and Keypad outputs 13.8V DC-0.6A
Battery Charging Current (Max.)	550 mA, current limitation
Battery Test: Indication at keypad or remote indication via communicator	Performed at 0.5A load for 1 second. Low Battery indication below 10.5V Tested upon Arming, and every 4 minutes during Armed, every 1 hour during Disarmed
Standby Power Consumption at disarmed mode, and Keypad display is Off	110 mA, +/- 10 %
Max. Remote Station (Keypads)	Five keypads AV-701TS, AV-701TI, AV-702. Eight AV-707 keypads
Remote Station Current Consumption	AV-701TS: 27mA. AV-701TI: 36mA AV-702: 40mA.
Housing (AV-2055D, AV-2088D in ABS plastic box)	ABS plastic
Housing Dimensions (AV-2016D)	(H) 32, (D)9, (W)36 cm
Housing Dimensions (AV-2055D, 2088D)	(H) 30, (D) 9, (W) 23 cm

Gross Shipping Weight (2055D, 2088D)	AV-2000: 1 kg. Six units per master box
Gross Shipping Weight	AV-2016: 3.6 kg. Three units per box
Fuses: Electronic Fuse	Auxiliary Power: 1.5A Electronic Keypad Power (2016): 1.5A Electronic Sirens: 1.5A Electronic Backup Battery Fuse: 3A Electronic

Av-Gad Systems Ltd. reserves the right to modify and upgrade products without prior notice.

Electronic Fuse Overview

The Electronic Fuse device included as a series element in electric circuit. In response to an over current it protects the circuit by going from a low-resistance to a high-resistance state that reduces the current to a level that's safe for the circuit elements. The change in resistance is the result of a rapid increase in the temperature of the device. Like traditional fuses, Electronic Fuse devices interrupt the flow of dangerously high current. However, unlike traditional fuses, they automatically reset after the fault cleared and power to the circuit removed. Because they are solid-state, Electronic Fuses are also better able to withstand mechanical shock and vibration, and provide reliable protection in a wide variety of applications. In case of over current, carefully touch the fuse body (yellow round disc), hot body means the Electronic Fuse in protection mode, disconnect the load and wait 2-3 minutes until the fuse body get cooler.

Tips to first time installer

If you are a first time installer, do not hook up any remote sensors at first. The most common confusion comes about when the **alarm will refuse to arm**, because a zone is “troubled”. Complete the power supply, siren, keypad and strobe wiring, and for the moment connect ALL the zone terminals to –V. This will simulate a system with all zones looped out through closed switches. The alarm is supplied already programmed with an “average” list of settings (default) and can be used straight away, a few of the program locations may have to be changed to suit the actual sensors and output devices used.

- 📖 Read this manual carefully, it looks complicated, but all the information is there
- 📖 The AV-2055D, 2088D, 2016D and AV-2016DP support LED keypad only; do not connect LCD keypad
- 📖 To start with: Hook up the keypad, connect all zones to –V, power-up by applying AC only
- 📖 In case the keypad (LED or LCD) displays ‘garbage’ verify the minus (-V) wire connection
- 📖 Arm and disarm the system, when the Status LED light (not blinking), enter your master code; 1234
- 📖 Try the hold-down functions. Hold each key for approximately 2 seconds; follow the confirmation letters in keypad’s display. In the PRO panel press the # to confirm the hold down command
- 📖 Set the system time by holding-down key ‘0’ then ‘1’, set time in 24H format, blinking ‘h’ stop
- 📖 The default programming is set for siren alarm device that requires 12V to alarm (Bell Mode)
- 📖 Connect the **Strobe Light** to the SLO output (requires programming). The SLO supplies –V during alarm
- 📖 Make sure you are using the Earth terminal  for Grounding; it is not a minus terminal
- 📖 Typing six erroneous codes will lock the keypad keys for 30 seconds
- 📖 Fast test: Verify “Dial LED” self test at initialization (STI) - Blinks for the first 50 seconds after power on, confirms panel is operative, from keypad wait to six beeps to confirm communication OK.

SECTION II: INSTALLATION

System planning

When the panel reaches you features set at “Factory Defaults”. This done for testing purposes and for simple installation without first entering to programming. This present program is referred to as ‘Factory Defaults.’ The engineer should be familiar with all the features and options before attempting to program. System supplied with or without transformer according to approval requirements in each country. Specify and order the keypad (several types available). Default arming code is 1,2,3,4. Default programming code is 1,9,9,4.

2. MOUNTING

2.1 □ Control Panel Mounting

Refer to detailed wiring diagram on section V. Note: ‘h’ is displayed after power-up to remind installer and user to set the system time; ‘h’ sign disappears after time setting (by hold down keys 0 then hold down key 1, refer to page 26).

Select a mounting location accessible to the following:

1. A continuously powered (non-switched) AC power source, compatible with step-down transformer. Make sure the mains (110 or 220V) are fused
2. A cold water pipe Ground, ideally no farther than 3 meters (10 feet) from the panel. Use 16 AWG (0.5 mm² wire)
3. Telephone line socket

Always install the control panel box in a hard-to-access location.

Locate one of the Keypads near the Entrance/Exit door.

Install a tamper-switch to prevent opening or removal of the control panel box. Connect the tamper-switch to a 24H zone.

Zone Wiring Mode

Via programming, select either End-Of-Line (EOL) Resistor Protection, or non-EOL mode.

If EOL mode selected (recommended), install the EOL Resistor (2.2K/0.25 or 0.5W) inside the detection device (e.g. PIR, Magnetic Switch). To disable EOL enter ‘0’ to EOL zones address.

Note: ‘Zone’ and ‘Sector’ are interchangeable terms in this manual.

IMPORTANT! Never run wire zones alongside telephone wires, high voltage wires, or transmitting antennae. Test your system daily.

Double-Pole Zone wiring

This feature saves on wiring and doubles the zone quantity by using two wires instead of four, for both TAMPER and ALARM indications.

Use always an EOL resistor; EOL prevents EMI and RFI interference

To activate Tamper Alarm, fit the zone with two EOL resistors, program 'Enable Zone Tamper' feature (address number 144, 145, 146, 147) and enable 'EOL Resistor Zone', entering the data at address (140, 141, 142, 143).

To enable the EOL mode program the zone selected as EOL zone. For example: To enable zones 1, 2, 3 as EOL zones; in address 144; program 1, 2, 3 removed.

Any EOL zone will report Tamper alarm in case of zone shorting (if it has been EOL programmed). To enable Tamper zone as 24H zone refer to address 075/1.

Upon Tamper alarm, a 't' displayed, followed by the zone number. To disable Tamper alarm, hold down key '9'. To display Tamper zone history, hold down key '0' then key '3'.

Use PIR, other sensor or Siren box alarm device that contains two separate switches or relay contacts: One for Alarm and one for Tamper. Connect each contact to a different EOL resistor. Alarm contact connected in series with 2.2K and Tamper contact with 4.7K resistors. Both resistors supplied with each system.

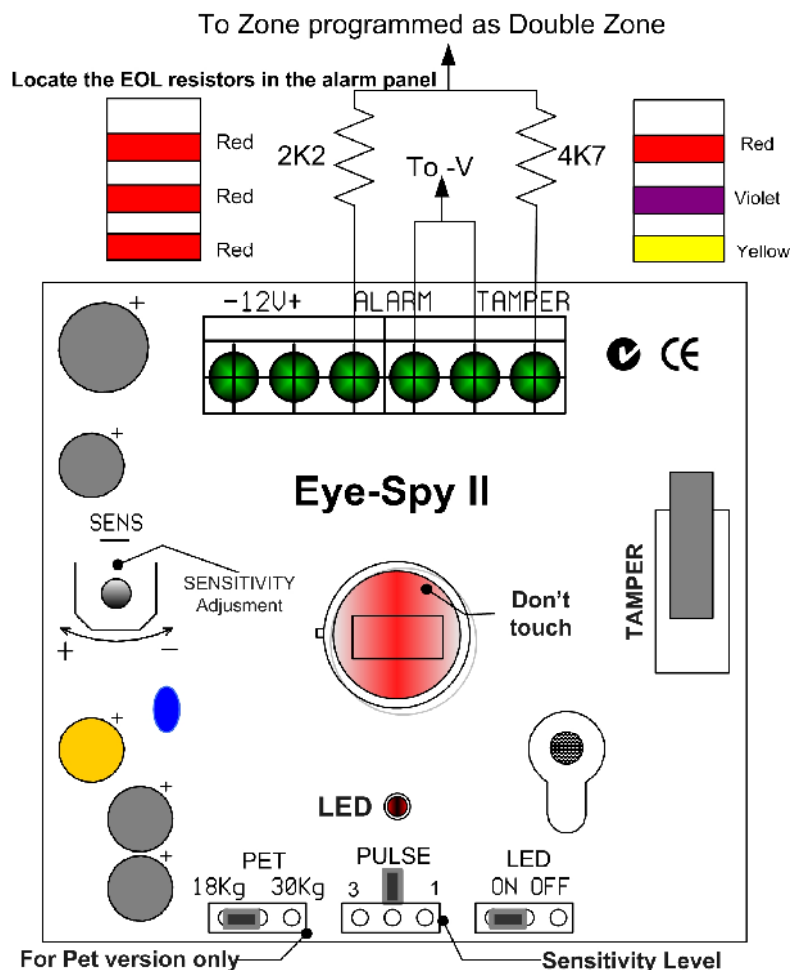

Figure 1: Double-Zone Wiring to EYS II PIR

Some countries are used to different double-pole wiring as shown in figure 1A. For this wiring, follow the drawing. European double-pole wiring requires 1.5K resistors (1.5K resistors not supplied).

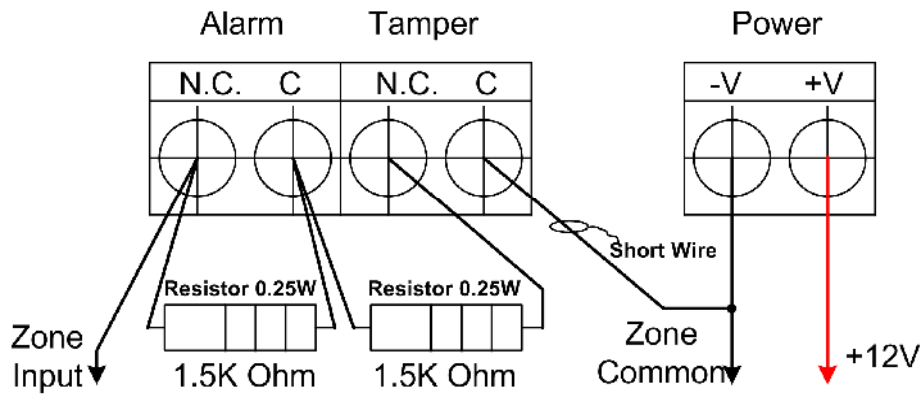

Figure 1A: European Double-Pole wiring drawing

2.2 □ Connection of AV-816 Expander

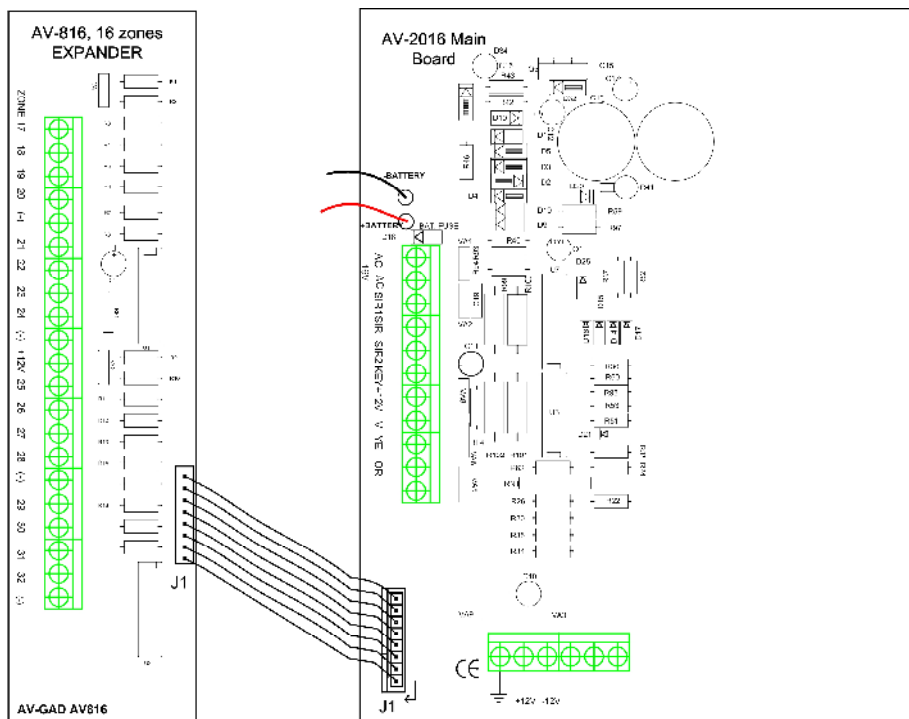

Figure 2: Zone Expander Wiring

Mounting

Place the AV-816 board on the left side of the AV-2016 board as the drawing shows. Use two screws to tighten the AV-816.

Connection

Make sure power and battery are disconnected.

Plug the wires connector of AV-816 to J1 socket at the AV-2016, refer to figure 2 drawing.

Zone Wiring Mode

Via programming, select either End-Of-Line (EOL) Resistor Protection, or non-EOL mode. If EOL mode selected, install EOL Resistor (2.2K/0.25 or 0.5W) inside the detection device (e.g. PIR, Magnetic Switch).

To enable EOL mode programming and resistors required.

To enable the Tamper Alarm of each zone, refer to the programming table and set the required zone by programming address number 144, 145, 146, 147.

Wiring details are available in the AV-2016 manual, see Double-Zone wiring chapter.

Programming

Program the 'Zone in Use' feature for the required zones (address 102 and 103). By default, program zones 1-16 set as 'Zone in Use'.

2.3 □ AV-2055D, 2088D Wiring

The AV-2088D contains eight zone terminals. Via programming, the panel becomes 16 zones, when zone doubling used. Adding the AV-208 the panel expand to 32 zone. Refer to figure 3. AV-2088D is compatible with AV-701, AV-702.

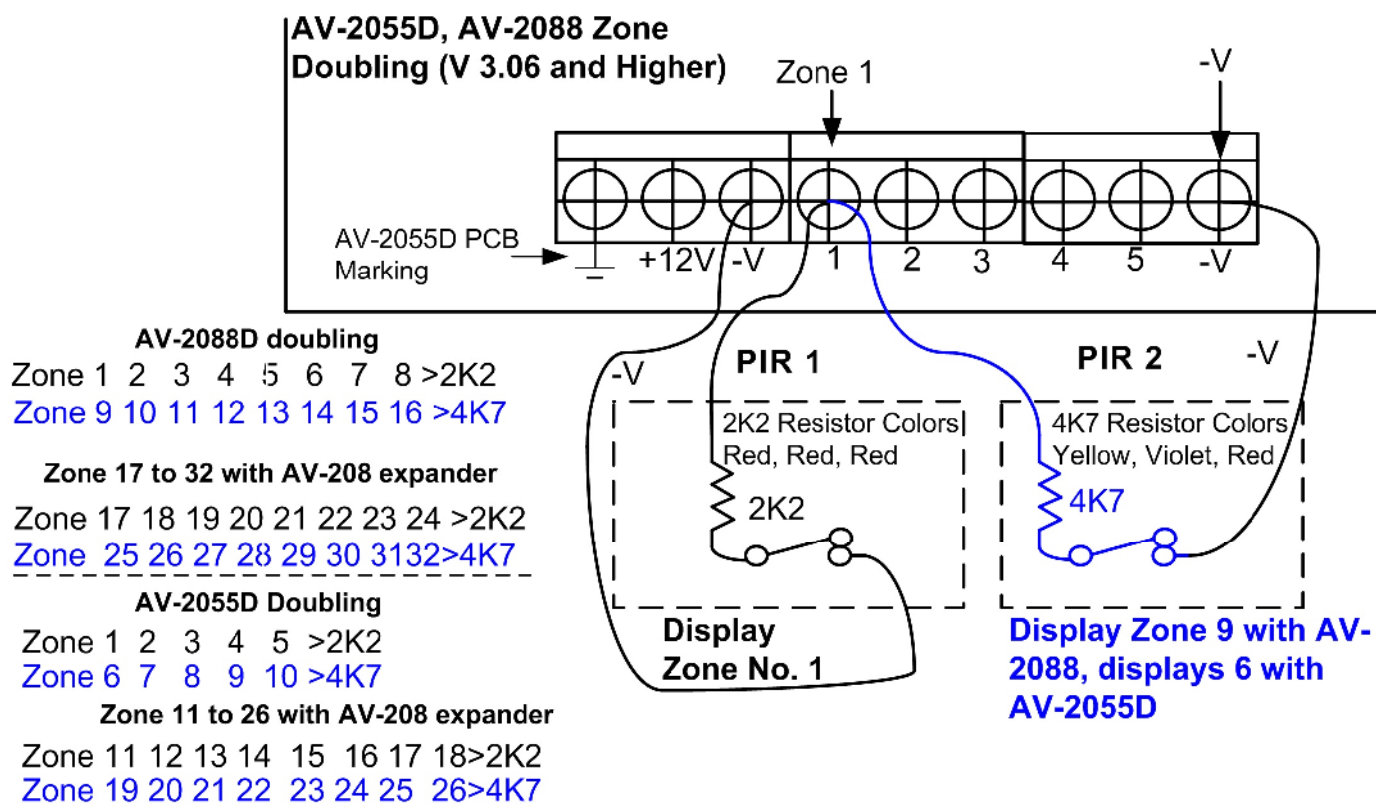

Figure 3: Zone Wiring AV-2055D, AV-2088D

AV-2055D: Default is five zones. To expand to 13 zones add the AV-208 expander board (not supplied). Zones on the expander counted zone 6 to zone 13. In ABS box insert the AV-208 in the left side of the box (grooves to fit), in metal box use the four supplied spacers).

In "Double Zones" mode (074-8, must use EOL resistors) both board and expander zones are doubled. Program the relevant zones as In Use (address 101), it provides 10 zones on the main panel board (1 - 10).

Zone 6 connected to terminal 1, 7 to 2, 10 to 5.

Using an eight-zone expander in double zone mode: First zone on the expander count as zone 11. Zones are counted 11 to 18 - connected to terminals 9 to 16 on the expander (use 2K2 resistors). Zones are counted 19 to 26 - connected to terminals 9 to 16 on the expander (use 4K7 resistors).

Zones on panel: 1 2 3 4 5. Zones on expander: 6 7 8 9 10 11 12 13 (without resistors)

Double zone: 1 2 3 4 5. Zones on expander: 11 12 13 14 15 16 17 18 (2K2 resistor)

Double zone: 6 7 8 9 10. Zones on expander: 19 20 21 22 23 24 25 26 (4K7 resistor)

2.4 □ Keypad Wiring

Up to four AV-701TS/TI, or five AV-702 Keypads can be connected to AV-2016D Control Panels, maximum three keypad with AV-2055D, 2088D. Use only AV-701 or AV-702 keypad. For more keypads, add external power supply.

Important: Consider adding a power supply when using more than max. keypads

Connect all keypads in parallel. Do not connect keypad with power on. Each keypad contains four wires terminal:

Red ➤ (+) Power, connect to + Aux. Power **Orange** ➤ System Data, connect to OR

Black ➤ (-) Power, connect to - Aux. Power **Yellow** ➤ System Strobe, connect to YE

For proper connection, refer to wiring diagrams on next page and at the end of the manual.

IMPORTANT! Never run Keypad wires alongside telephone wires, high voltage wires, or transmitting antennae. Wire the keypad wires separately and not in same cable with other devices (telephone, PIR sensor etc.). Do not use the keypad wires for supplying power to sensors or other devices. Keypads have no polarity protection; verify 12V power carefully during wiring.

- Wire length for each AV-701 keypad better not exceed 100 meters (using 0.5 mm² wires).
- If installation requires keypad wire length of more than 100 meters, or more than five keypads:
 1. Add a 470-ohm resistor between +12V and YE terminal in the control panel
 2. Use two wires for the -V that supplies the keypad power
- Maximum wiring length for AV-706, AV-707 and AV-702 keypads is 200 meters (when using 0.5 mm² wires).
- Power at Keypad should be a minimum of 11.5 Volts.

Note: If a non-blinking '8' displayed and keys do not respond, it is an indication that the keypad is not communicating with the panel. Check wiring. Polarity error may blow the panel fuse.

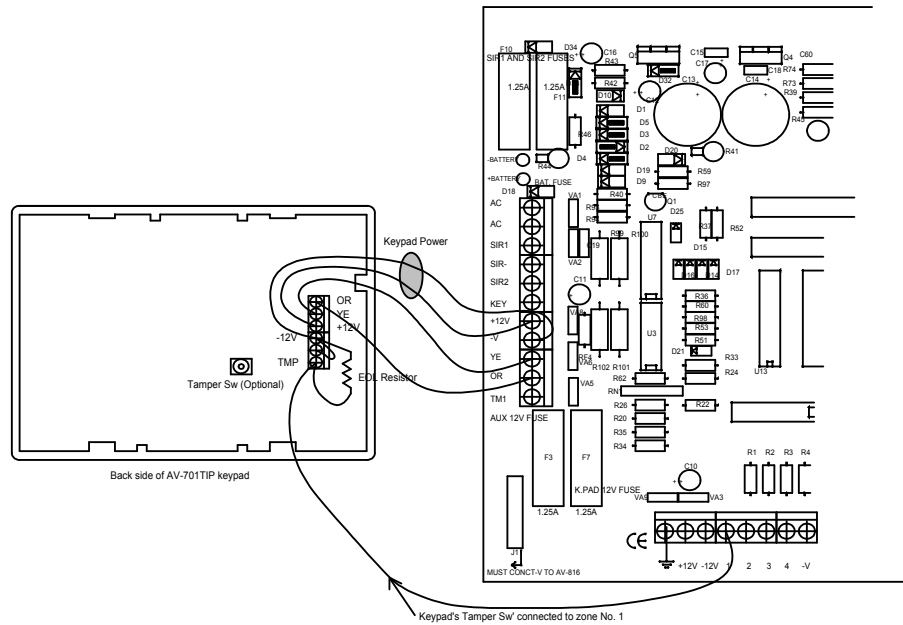

Figure 4: Wiring Keypad AV-701TS/TI, AV-701TIP

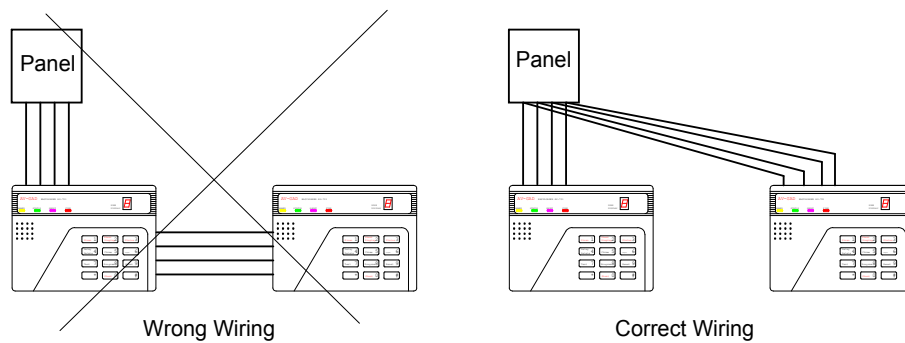

Figure 5: Best way wiring keypads

For trouble free operation follow the recommended wiring as shown in figure 5 drawing, wire each keypad to the panel directly, avoid to run wires from one keypad to next (as shown the on the ‘Wrong Wiring’).

Keypad Tamper Switch

The AV-701TIP, AV-702TP keypads (keypad with tamper switch) contain a Tamper switch that activates upon trying to remove the keypad after installed. Connect the Tamper switch to Tamper, Day or 24H type zone. For connection, refer to keypad’s wiring diagram.

3. ALARM OUTPUTS

3.1 Sirens

- Control panel enables driving of two separate speaker sirens or bells.
- Speaker siren issues a multiple-tone alarm. Use 14W, 8 to 16 ohm speaker siren.
- Bell mode (sounder that works on 12V DC) is available via programming.
- Enclose the outdoor siren in a metal box tamper-switch protection.
- Protect siren or bell box with tamper-switch connected to a 24H zone.
- The control unit contains two siren outputs, for internal and external siren, individually protected by fuses.
- If Siren mode selected, use speaker type siren with a minimum power of 15W, 8 Ohms impedance. Enclose the outdoor siren in a metal housing, with anti-tamper switch protection.
- In Siren mode, install only speaker-type sirens, which DO NOT contain sound driver or electronic modules.
- The alarm issued by the Siren (not Bell mode) differs according to the type of zone.
- ‘Bell Mode‘ is default-set at factory. Bell converts Siren outputs into 13.6 VDC outputs (no sound is issued). Bell mode is applicable for driving self-powered sirens or bells, or combined sirens and strobes.
- In Bell mode, connect **only** Bell or sirens that contain a 12V sound electronic driver module. Bella sirens are compatible and feature high sound level at very low current use.
- Self-contained Bell mode is programmable (address 071). This mode allows connection of Bells or Sirens that require 12V at ideal and 0V during alarm. The Bell output voltage regulated at about 13.6V. For self-contained siren, it is recommended to use Av-Gad Bella 2 or Bella 3 siren, both with Xenon strobe light.
- Some Piezo siren generate high voltage spikes that may reset the panel, in such cases connect the + siren to +Battery (battery + lug) and – siren to –SIR in the panel.

Warning!

Output power for each siren should not exceed 0.7A (total Bell output is 1.4A).

- Contact manufacturer's consultant before connecting higher power loads.
- To connect self-contained sirens, Bells, and inner-oscillating sirens, refer to address 072; see Bell mode.
- Contact manufacturer's consultant before connecting higher power loads.

3.2 Remote Indication Terminals

Indication	Application
ON	(-V) on closing (Arming)
OUT 1 (A1)	Programmable. (-V) during alarm from the programmed zone or event (tamper alarm or panic)

OUT 2 (A2) AV-2016 only	Programmable. (-V) during alarm from the programmed zone or event (reset, tamper alarm or panic)
SLO Output	Programmable. (-V) during alarm from the programmed zone Resets only upon disarming (SLO is a non-timed output). Most useful for strobe light connection.
SLO 1 Output	Programmable. (-V) during Smoke reset or Code 7 entry

Warning: The remote indications are capable of driving maximum 300 mA, overloading or applying +12V to the remote indications is dangerous and not assured by warranty

To drive a low current Strobe Light (Xenon) consuming up to 300 mA, connect the strobe to SLO.

Beginning with version 2.08, a new feature enables programming the listed outputs to supply float output (0V) during alarm and -V at ideal. Refer to address 073-8.

In case other features selected for the same output, this feature is not applicable.

When connected a relay the remote indication, connect a diode must to the relay coil in reserve polarity to the supplied voltage, or use AV-01/02 relay module. For LED driving, connect a 2.2K resistor in series.

Hardware Tests for Outputs (starting version 2.17)

This feature enables testing of devices connected to the remote indications.

In programming mode, using 200 + 30 to 43 commands (SLO1 exist only in AV-2016 panels):

- | | |
|-----------------------|------------------------|
| 30 - On Output: ON | 31 - On Output: OFF |
| 32 - A1 Output: ON | 33 - A1 Output: OFF |
| 34 - A2 Output: ON | 35 - A2 Output: OFF |
| 36 - SLO Output: ON | 37 - SLO Output: OFF |
| 38 - SLO1 Output: ON | 39 - SLO1 Output: OFF |
| 40 - SPARE Output: ON | 41 - SPARE Output: OFF |
- PRO only: 42/43 LCD display - Display pattern test

3.3 Wiring and Connection of Relay Module

The Relay Module enables connection of *EasyLoader* 2000 Series panels to most types of Bells and self-contained internal battery Bells or Sirens (the term ‘Bell’ will apply to both Bells and Sirens).

Trigger the Relay Module via the siren output of the control panel. The power which drives the Bell supplied from the Aux. Power of the control panel, or from an external power supply in case the Bell requires higher current than the 0.7A supplied by the control panel.

Full installation details enclosed with the relay module.

4. WIRING AND POWERING UP

4.1 □ Grounding – Lightning Protection

The control panel must be earth grounded for lightning protection to work effectively, and in order to prevent RFI and EMI interfaces.

Attach the ground connection to a verified cold-water pipe using a minimum 16 AWG (or larger) wire, or according to the country-grounding standards. Run the ground wire via the shortest possible route.

System grounding is compulsory. For trouble free system, use a good ground.

Connect the Grounding wire to main board and to the metal box.

Note: Connect the Ground wire to the terminal marked . This is not a Minus (-V).

Beware of static discharge; before handling the main board touch a grounded metal.

Before grounding the system, make sure ground properly connected and does not transfer high voltages. If ground is not available, run a ground wire and connect to a cold water pipe as close as possible to earth.

4.2 □ Back-up Battery

Connect the Battery in the correct polarity!

- The system's Red wire is the positive pole (+) and the Black wire is the negative pole (-).
- The battery will provide power back-up in case of AC power failure.
- Connect back-up battery to ensure proper operation of the system.
- Recommended battery: 6.0 to 7.2 Amperes per Hour (AH), 12V SLA (Sealed Lead Acid) type. The AV-2016 box is ready for extra AV-21 power supply and 5003TER transformer.
Notice for connecting extra power supply: Power the keypads from main board and sensors from the AV-21 or other external power supply, do not connect the –V (minus) from power supply to the main board.
- 7.2 AH battery provides power back-up to control panel and to a single keypad for approximately 8 hours. With LCD keypad, the backup time is to 6 hours.
- AV-2016 accommodates two 12V - 7.2 AH battery. Do not connect two batteries in series or parallel. Contact us for instructions.
- An Electronic Fuse protects the battery circuit.

4.3 □ Before Powering Up

- Place the Control Panel in a well-ventilated location, as far as possible from heat sources.
- High power RF transmitters place at least 2 meters away from the control panel.
- Check for proper grounding. Discharge your body by touching the Ground terminal.
- Make sure polarity of detectors, keypads and other devices is correct.
- Connect a momentary voltage to the siren; making sure a ‘beep’ sounded. If there is no beep, check for a short circuit or improper connected wires.

- Initial powering-up with AC transformer (without the battery). Connect battery only after keypad and sensors seem to be operating well. (Do not Power-up with battery alone.) Verify power polarity of keypads.
- Do not connect any devices to the battery terminals.
- The alarm panel contains Electronic Fuse, in case the fuse blows return to factory for replacement. Refer to further details at page 9.
- Observe the dial LED self test at initialization (STI) - Dial LED blinks for the first 50 seconds after power on, confirms that the panel is operative. Also, wait for the six beeps from the keypad to confirm that the keypad is communicating with the panel.

4.4 □ Connecting Smoke Detectors

Series 2016 accommodate Ionization or Optical type 12V Smoke Detectors. Connect up to five smoke detectors to each zone. Most smoke detectors are Open Collector output, the wiring and programming depends on the smoke sensor you are using, on general program the zone as Fire, Normally Open (N.O.) zone type is automatically enabled and EOL. It means; a zone programmed as Fire (but no EOL) the zone will also be N.O. type. In this case, do not connect the EOL resistor as wiring diagram show. The smoke detector LED will remain constantly lit and the relay or output will remain in ‘Alarm’ until the smoke detector power is disconnected for a short while (reset).

- The AV-2055D, 2088D and 2016D are compatible with 12V smoke detectors with open collector or relay (-) output on alarm.

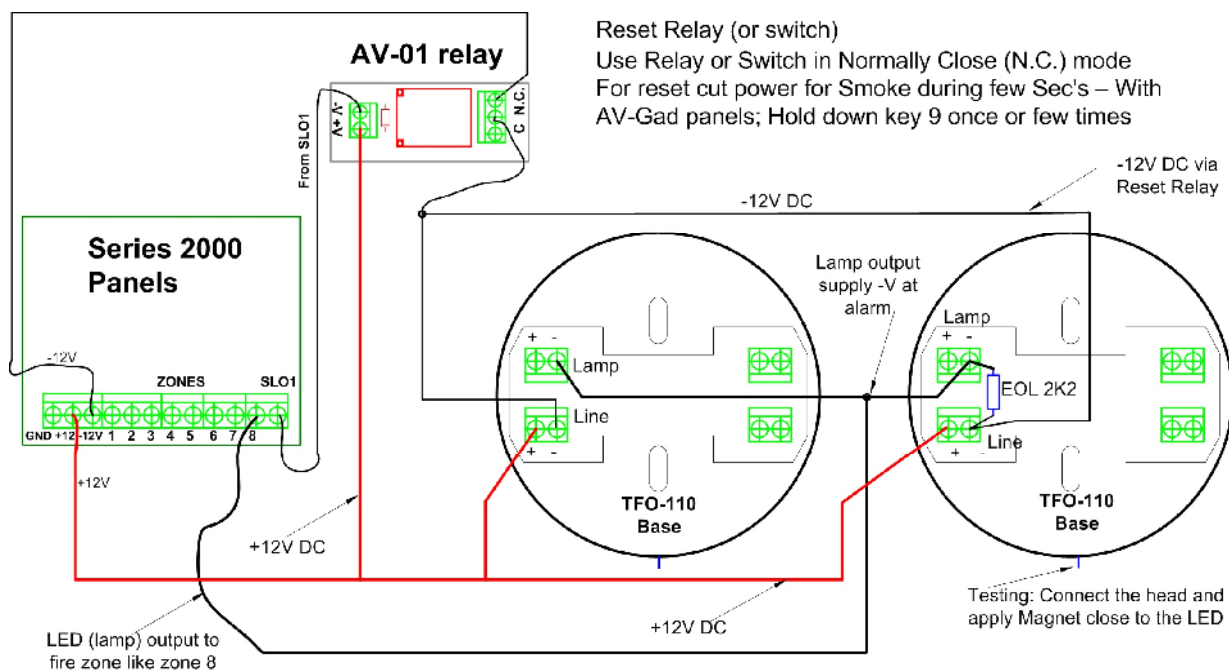

Figure 6: Smoke Detector Wiring (TF smoke series)

- To reset smoke detector program the SLO (AV-2055D, AV-2088D) or SLO1 (AV-2016D) output to drive -V while holding-down key 9 (a momentary switch or relay that disconnects power to smoke detector after a smoke alarm). Refer to smoke wiring diagram on this page.
- When Fire Alarm occurred, hold-down key ‘9’ for reset, enter valid code to disable alarm.

4.5 □ Telephone System Dialing

It's recommended to connect the control panel to an independent telephone line, if a device is in parallel with the alarm panel, this may grab the call first (like a message answer/fax) during remote up and download.

Do not connect fax or answering machine in parallel on the same telephone line.

In case of alarm the dialer dials to the programmed numbers, siren sound or voice message (if SVM-40 connected) transmitted to the telephone. The voice module will apply spoken message over the telephone upon alarm.

Default dialing mode is DTMF. If PULSE dial selected, the default is European Make/Break rate of 40/60 milliseconds (in Pulse dialing). The Make/Break rate is programmable.

Dialing mode is programmable (refer to programming sheet addresses 088 and 089).

Connect the telephone line to 'TEL-LINE' terminal, if handsets connected to same line connect them to 'PHONES', when system attempt to dial the 'PHONES' disconnected. Do not connect to ISDN or other digital telephone system. Most ISDN converters have an Analog line; connect the Analog line of the ISDN the TEL-LINE terminal. Option: To protect your line add the Tele-Spy, it is a 24H telephone line monitor separate module. Note: To perform telephone line test enable Dial Tone detection at address 083.

For AUSTEL installations: At address 074 enter 8, at address 087 enter 2 (maximum), don't connect any phones in parallel with TEL-LINE terminal. Software Dial Tone telephone monitor is included, refer to address 094, 076 options 5,6. Dialing problems may occur when system telephone line is connected to Telstra Duet system or similar.

4.6 □ SVM – Voice module

The *SVM-40* and *SVM-60* speech modules allow the recording and playback of two messages, with optional playback through an external speaker (not included). *SVM-40* message duration is 40 seconds; *SVM-60* message duration is 60 seconds. The SVM contains an on board microphone.

The *SVM* is a high technology device, electronically stores messages with or without power.

The *SVM* is as a digital message source in Series 2000 Alarm Control Panels, telephone dialers or in other applications. The *SVM* supplied audio is capable to drive audio amplifier, message center, automatic dialer or other device.

When connected to Series 2000 Alarm Control Panels, program the SVM option (at programming table 072-7). Follow the wiring procedures (included in SVM manual) simulate alarm, the panel will dial first the Communicator telephone number (telephone number 2 and 3), then dial to other programmed numbers.

After dialing, the panel will trig the SVM to send the recorded message. If address 071 (1) is programmed Telephone 1 is erased within arming and disarming.

4.7 □ Remote Key and Wireless Arming & Disarming

- The AV-2055D, 2088D, 2016D enables Arming/Disarming by remote momentary or latch key-switch (as programmed in address 071), which is connected to terminals 'KE' and '- Aux. Power'.
- When using remote key-switch, wire length should not exceed 10 meters.
- A Momentary pulse (momentary trig) between 'KEY' and '-V' terminals will Arm and Disarm the control panel. (Before arming close 'instant' and '24H' zones)
- System reverts to previous status with next momentary pulse. (Refer to AV-2016 Wiring Diagram.)
- Arming by key will cause a long beep at the keypad if "Enable two siren beeps at disarm" (073 - 6) is programmed.
- For Arming/Disarming via Wireless Radio Remote, connect receiver's relay to 'KE' and '- Aux. Power' terminals. Verify the receiver relay mode, momentary, or latch, and set system accordingly.

4.8 □ Remote Access via DTMF

General Description

Remote DTMF enables remote control of the alarm panel from a DTMF phone, this unique feature provides Home Automation function and other functions as detailed below.

DTMF commands are possible when the panel call your phone, or by calling the panel. The DTMF remote control functions:

- ➔ Check the status of the control panel (Armed/Disarm, Alarm in progress)
- ➔ Arm or disarm the control panel
- ➔ Bypass zones or clear all bypassed zones
- ➔ Stop the dialer report during alarm
- ➔ Momentary activate A1 (alarm) output for three seconds
- ➔ First Alarm indication - by a number of beeps per zone, special tune for Panic alarm

The same options are available when a call received from the control panel during an alarm condition.

To enable the DTMF control program address 076/4 "Enable remote access by telephone", and 076 - 2 "Enable A1 activation by telephone".

In AV-2016DP, only User 01 (master) allowed to Arm, Disarm and Bypass zones, all other functions are accessible to all users.

Keypad online conformation and DTMF functions history

When the control panel detects the first DTMF key, five short beeps at the keypads. The keypad activation shows the user at the remote site that a DTMF connection takes place (in case of mistaken connection or similar).

During the remote access the keypad display 'd' and all LEDs blink fast from time to time.

At call ends, three short beeps sound at the keypads. When the user code is in process, the keypad display shows a line for each code number entry (disclose the code), then each DTMF number pressed show the received number.

History log: Each call, confirmed by a valid user code, Arming/Disarming and other events made by the remote DTMF phone are recorded in the event history.

"Last users" history will display 'ut' for "user "telephone, followed by the User number.

Notes: 1. The keypad buzzer or other loud sounds may jam your DTMF entries, in case the keypad is close to your DTMF telephone, during testing disable the buzzer.
2. When entering the DTMF commands wait for “quit” period, if entering commands during the system confirmation tunes, or other tunes the panel may miss the DTMF entries.

The panel calls the user during alarm

When the control panel calls the user during alarm, it will first generate the siren sound for about 30 seconds (to shorten this feature at address 085 "Tel. Message Time", to 30, as default is 50 seconds). The siren sound will stop ten (10) seconds before the end of the call and a greeting tune will be sounded, after the greeting tune enter your code followed by #.

To stop the dialer enter 6#, to get panel status enter 7#, to disarm the panel enter 2#. Press 9# to end the process.

The control panel will answer the call after the number of rings programmed at address 091 (or following the "bypass answering machine" procedure).

Commands

Each command must be followed by the '#' key (Enter) in the remote phone. The control panel waits 4 seconds between the keys typed. When this time expires, previous keys input will be discarded.

The key '*' cancels previous input. It is recommended to start with "learn" function [8X #] to identify the various confirmation tune.

The commands:

[0 X #] - **Bypass zone** (# is the Enter key)

X is Bypassed zone 1 to 8

To clear all bypassed zone: 0 9 #

The zone bypass command is valid only when the system is in Disarm position and not in Alarm position.

[1 #] - **Arm the control panel.** The control panel arms even with open zones. After the arming, a confirmation tune followed by an "armed" tune heard ("Armed" tune: Short beep followed by a long tone.).

The user can wait a few seconds to be sure that no alarm caused by open zones. In this case, an Alarm tune (siren sound) sound.

[2 #] - **Disarm control panel.** When control panel disarmed A confirmation tune followed by a "disarmed" tune heard ("Disarmed" tune: Five short beeps).

[31 #] - **Activates A1** output for 3 seconds (enabled by programming 076-2)

[33 #] - **Activates SLO** output for 5 seconds, keypad sounds 7 short beeps (enabled if SLO is not used with zones alarm events or for Chime activation)

[6 #] - **Stops dialer.** The dialer will stop calling the programmed telephone numbers. This will affect only the current dialing process. A new alarm will re-start the dialer.

Note that if the user answered a call from the panel or called the panel during a dialing period without Arming/Disarming/Stopping the dialer, the dialer will restart the cycle from the beginning.

[7 #] - **Check control panel status.** The control panel will answer with an Armed or Disarmed tune followed by an Alarm tune if it is in an alarm condition.

[7 and 7 #] - **First Alarm Zone Report,** beeps count for the zone number. Report user the first zone that caused alarm. Arming or Disarming clears the First alarm zone reported by DTMF.

Zones 1 - 10: 1 to 10 short high tones

Zones 11 - 19: One long low beep for 10 followed by 1 to 9 short high beeps.

For example, zone 14: Reported as one long - low beep followed by four (4) short beeps.

Zone 20: Two long - low beeps.

Zones 21 - 24: Two long - low beeps followed by 1 - 4 short high beeps.

[8X #] - **Learn function tunes.** Using this command, the user can become familiar with the various sounds used by the control panel in the remote access procedure. Further details find in the dedicated paragraph. (X - The required sound).

[9 #] - **End call.** The control panel will sound a confirmation tune and will hang up.

SECTION III: AV-701 & AV-702 DIGITAL KEYPAD

1.1 □ Standard Keypad Functions

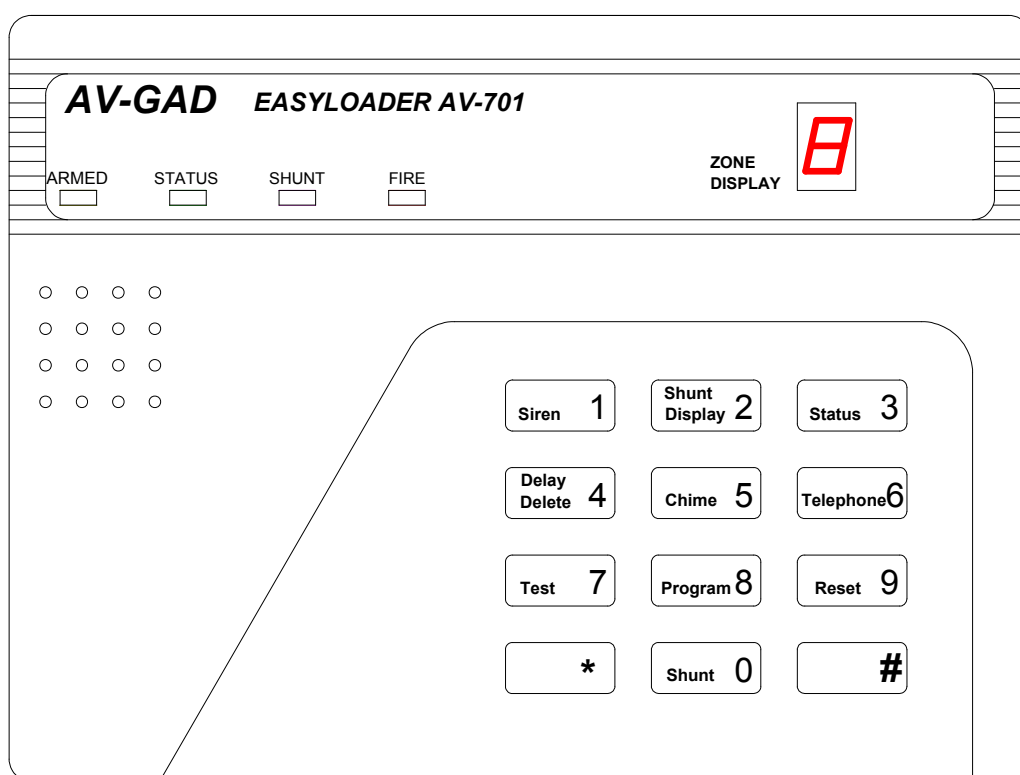

Figure 7: AV-701 Keypad Layout

Common Terms in this Manual

- **‘SHUNT’ and ‘BYPASS’ are interchangeable terms**
- **Program Mode - Enables features programming, ‘P’ is displayed, alarm is disabled**
- **Use Mode – System disarmed and not in alarm or program mode**
- **AV-701TS, AV-701TI or AV-702 are identical**

- Standard Keypad functions are accessed by pressing keys (short press). The 1 to 0 keys used for Arming/Disarming (ON/OFF), Zone Shunt (Bypass), and other programming functions.
- A short beep confirms each key press.

A short press on keypad key accesses the following special functions:

Chime **5**

Instant Arming, by pressing key ‘5’ (requires programming).

Shunt **0**

Zone Bypass, by pressing key ‘0,’ followed by entering the Zone numbers 01 to 32.

Shunt **0**

Zone Bypass Via Code (requires programming, see address 071).

Press key ‘0’, while 4 LEDs are blinking, enter user code No. 1; When the 2 left- most LEDs are blinking, enter zone number(s) (2 digits format) to be bypassed, four LEDs stop blinking, ‘Shunt’ LED remains on to confirm zone bypass. Within 20 seconds, enter your user code to Arm the system. Note: Zone Bypass via Code is standard in AV-2016DP.

Shunt **0**

then

Shunt **0**

Shunt **0**

Group Bypass, press 0 and two presses on key ‘0.’ Group-Bypass is operative only if system armed within 60 seconds from the entry of this feature. Yellow LED will flash and ‘h’ (Home) displayed for 1 second in confirmation.

Shunt **0**

and

Shunt **0**

. Press key ‘0’ twice for Group Bypass. Operative only if system is Armed within 20 seconds after entry of this feature. Yellow LED will flash; ‘h’ (Home) displayed for 1 second in confirmation.

Starting version 2.13 PRO only: To activate Group Bypass II press key ‘0’ three times. To activate both group bypass groups, press 0 then 88.

From version 2.04 and on, when Group Bypass is selected, the buzzer and LEDs react as follows:

- Shunt LED stops blinking 8 seconds after Arming, (prevents LED light from disturbing sleepers near the keypad)
- There is no exit/entry delay-warning buzzer, and keys beep at the keypad.
- There are no ‘beeps’ at the keypad until an alarm occurs, or until Group Bypass is canceled.
- When the keypad LEDs are turned off after Arming (requires programming), touching the keypad will turn them on for 5 seconds.

Group Bypass with code (requires programming). Press key ‘0.’ While 4 LEDs are blinking, enter valid user code.

When only two left most LEDs are blinking, press ‘0’ key again, ‘h’ will be displayed and ‘Shunt’ LED will remain blinking to confirm Group Bypass. Enter your user code to Arm system. Note: Complete Group Bypass within 180 seconds or Group Bypass is voided.

1.2 Hold-Down Functions

- Holding down the key for approximately 2 seconds accesses hold-down functions
- Hold down functions are confirmed by a long beep

Hold-Down Functions:

Siren 1 Key 1 → **SIREN TEST**

Shunt Display 2 Key 2 → **SHUNT DISPLAY**
Displays shunted zone(s).

Status 3 Key 3 → **STATUS DISPLAY**
Displays troubled or malfunctioning zone(s).

Delay Delete 4 Key 4 → **DELAY DELETE (INSTANT PROTECTION)**
Cancels Entry delays in zones selected as ‘Delayed’ zones. All zones become Instant.
‘d’ is displayed in confirmation. Instant Protection becomes effective only if System is Armed within 20 seconds following hold-down of key 4.

Chime 5 Key 5 → **DOOR CHIME**
Enables Chime when opening zone. Door Chime operates on Chime-programmed zones. Hold-down key 5 enables and disables the function.
Chime mode is confirmed by ‘c’ display on keypad.

Telephone 6 Key 6 → **DIALER TEST & FOLLOW-ME PROGRAMMING**
Test is performed in ‘DISARMED’ mode.

Function	Via AV-701, 702 Keypad
Displays Programmed Follow Me Telephone Number Without Dialing	Hold-down key [6]
Follow Me telephone number programming	
Programmed Telephone number Verification (Display and Dial 4 telephone numbers)	Hold-down [6] then hold-down [7], number is displayed

Display programmed telephone numbers without dialing: Within few seconds, 'c' will appear on the display, followed by the (programmed) 'Follow Me' telephone number.

When programming telephone numbers that requires an inter-digit delay ('Pause') during dialing; Hold-Down key [0], a momentary 'P' displayed (Delay duration is 3 seconds).

The 'Follow-Me' number is displayed, or displayed and dialed, followed by display-and-dial of up to three additional telephone numbers.

Telephon **6**

and

Siren **1**

. Address 092 enables 'Answer Now' feature, the system answers remote computer after one ring. This feature is important if the control panel programmed not to answer incoming calls (programming of 21 rings or greater at address 091). To enable 'Answer Now' feature program 01 at address 092.

Hold-down key 6 and then key 1, before the computer and modem connect (dial) the control panel. The panel will acknowledge the command with two beeps and display an 'A.' The feature remains active for 5 minutes after entered, enabling to remotely program (from remote computer) the panel.

Other possibility to connect to a system connected on same line with a fax or answering machine is to use the "Answer machine bypass" feature.

Test **7**

Key 7 → **FAULT FIND**

- Fault Find enables testing of all detection devices.
- Fault Find mode is accessible only during 15 seconds following System Disarm.
- 24H, Fire or Panic alarm will stop Fault Find mode.
- Hold down key 7, confirmed by 'F' on Keypad display.
- Open and close each zone to test the zone regularity. A one-second beep confirms detection of zone opening. Three beeps indicate zone closing.
- Quit Fault Find mode by Arming the system.

Program **8**

Key 8 → **PROGRAM**

Key 8 accesses 'Program' mode and user code programming (changing).

Reset **9**

Key 9 → **RESET**. 'Reset' performs the following functions:

1. Cancels last Keypad entry
2. Stops the communication test (triggered by hold-down key 6)
3. Activates output 2 for resetting the Smoke Detector (requires programming)
4. Resets Day Zone Alarm at Keypad
5. Exits Programming mode (features, telephone numbers, etc.). For PRO and LED (version 3.04 and higher) panels enter 999 to exit programming mode

Key Zero Hold-Down functions

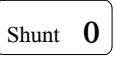
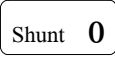
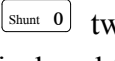
1.  Key 0 **Concise Alarm History**: Hold down key '0' to display the last alarm sequence.
2.  and  **Detailed Events History (requires programming)**: Hold down key '0' and again hold down key '0' to display up to 36 events, including: System opening and closing by user number, opening or closing time, alarming zone and AC fail.
By holding-down key  twice, three LEDs start blinking, to indicate a special operation mode. The events are displayed from the most recent event to the oldest.
At AV-701/2 keypad the events displayed as following:
XX - Event number (from 01 to 36), then HH_MM (Hour and Minutes) Event Time, Event (alarm or opening/closing).
Translate the display as following:
'u' (user number 1 to 16), 'o' or 'c' - opening or closing, Zone causing alarm will blink twice
tX - Tamper alarm from zone causing the alarm (X), H - Panic Keypad Alarm
Note: 3 lines (≡) indicate power fail. An AC fail event displayed during history events.

Event	AV-701, 702 display
Time set	'tu'
Date set	'du'
Installer programming	'IP'
User programming	'UP'
Factory defaults	'Fd'
Communication (to CS) failure	'CF'
Panic from Panic zone	'Hzz' (zz = zone number)
Keypad locked (code error)	'PE'
Low Battery	'Lb'

Table 1: Events as displayed at AV-2016D

Events display example at AV-701, 702:

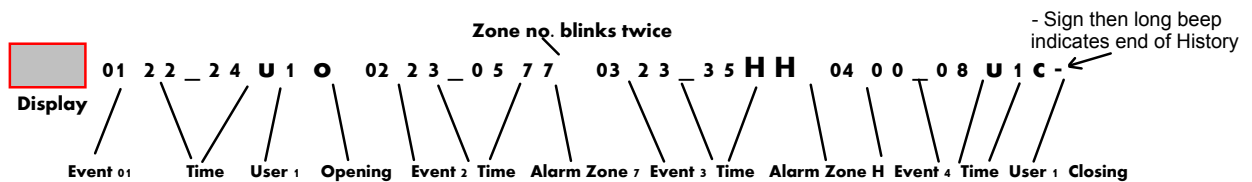



Figure 8: Events Log as Displayed at Keypad

During zone number display, keypad display blinks twice to indicate the zone number.

Browsing through Events History

Keys used for browsing:

 ➤ Skip forward to next event

- Chime 5 ➤ Display current event again
- Program 8 ➤ Skip backward to previous event
- Reset 9 ➤ Cancel History Event Mode and exit

Upon display of last event, if an attempt is made to move forward (key 2), a blank sign ‘-‘ is displayed, along with a warning beep indicating that this is the last event. Press key 8 may to move backward. If no key is pressed, Event History stops and system returns to Use mode.

When starting History Events mode the events are displayed from the beginning to end without any break, until any browsing key is pressed.

During History Events, browsing system will respond only to alarm or panic, Arming denied.

Alarm or Panic during History Event mode will quit this mode and system will set to Use Mode (normal operation mode).

For easier detailed alarm history, use the downloaded from panel to remote computer. History queue log of up to 99 events are displayed at the keypad and in the *EasyLoad* PC software.

4. Shunt 0 and Siren 1 **Display and Setting of System Time:** Hold down key ‘0’ and then hold-down key ‘1,’ 3 LEDs will blink. Wait for the display of system time in 4-digit format. To set new time, hold down key ‘0’ and then hold down key ‘1.’ Do not wait for time display; enter the new time in 24-hour format. The local clock time is not stored in system memory; adjust clock after power-up. After powering-up system, time is reset to 00:00, ‘h’ will be displayed to remind user to set time; ‘h’ will disappear after setting the time. If Auto-Arming enabled the clock setting is from user Programming mode only, refer to Auto-Arming section.

5. Shunt 0 and Shunt Display 2 **Display and Setting of System Date:** Hold down key ‘0’ and then hold-down key ‘2’; 3 LEDs will blink. Enter date: ‘dd mm yy.’ The up and download PC software displays time and date, along with event history. The local date is stored in system memory; adjust date after long power-fail.
 Years 78 through 99 translated as 1978 to 1999
 Years 00 through 77 translated as 2000 to 2077

5. Shunt 0 and Status 3 **Concise History of Tampered Zones:** Hold down key ‘0’ and then hold down key ‘3’ to display the Tampered zone alarm sequence. New alarm will create a new history event instead of old one.

6. Shunt 0 and Delay Delete 4 **Reset Events Memory (history):** Hold down key ‘0’ and then hold down key ‘4’ to clear all events from memory. Starting version 2.09, cannot erase the history log (former command ‘0’ + ‘4’).
 Instead, during the installer-programming mode, clear history by command 200+04.

7. **Shunt 0** and **Chime 5** **Display Last 2 Users:** Hold down key '0' and then hold down key 5 to display user number and System opening or closing time.
 'o' is displayed for Opening (Disarming); 'c' is displayed for Closing (Arming).

8. **Shunt 0** Press (not hold-down) and press **Reset 9** (not hold-down), will display '-' to cancel all Bypassed Zones.

***** Keypad Panic **#** Keys → **PANIC BUTTON**

Holding down * and # keys will trigger Panic alarm. H will be displayed (zone 'H').

**To cancel *Hold-Down* function accessed by keys [0], [6] and [7]; Hold-Down key 9 (Reset).
 To quit zero hold-down functions, hold-down '9'**

1.3 □ Keypad Sounder

The Keypad sounder enhances the use of system operation and serves as a local alarm device (requires programming).

The sounder emits sounds in the following instances:

OPERATION	SOUNDER RESPONSE
◆ Pressing of any key	Short confirmation beep
◆ Power up	Six beeps
◆ Hold-down functions	Long confirmation beep
◆ Faulty programming input	Long beep (+ 'E' display)
◆ Delayed Zone triggering	Three long beeps
◆ Exit delay starting (if programmed)	Warning beeps until the delay is over
◆ Completion of Arm/Disarm programming code	One long confirmation beep
◆ Programming Telephone numbers	Two confirmation beeps
◆ Completion of address programming	Two confirmation beeps
◆ Pressing 'Code 7' for driving door opening	Seven confirmation beeps
◆ Arming of System with Instant, Fire or 24H troubled zones	Five warning beeps + troubled zone display
◆ Feature programming	Two confirmation beeps
◆ Follow-Me number programming	Two confirmation beeps
◆ During alarm (requires programming)	Intermittent beep until alarm reset

1.4 □ LED Indicators

AV-701 and AV-702 Keypads: Four LEDs provide visual indication of System status, as well as confirmation of various modes.

Keypad LED's indication

Armed Led-Red	AV-2016	AV-2016DP
Off	System Disarmed	All partitions Disarmed
Blink slowly	An alarm is triggered	At least one partition is armed
ON steady	System Armed	All partitions are ARMED
Blink fast	Mode does not exist	Alarm triggered in partition/s

Status LED-Green	AV-2016	AV-2016DP
Off	System Disarmed	Some partitions are Armed
Blink slowly	Some zones are open	Some zones are open
ON steady	All zones OK	All zones OK
Blink fast	Some zones have been tampered	Some zones have been tampered

Shunt LED-Orange	AV-2016	AV-2016DP
ON steady	Some zones are bypassed	Some zones are bypassed
Blink slowly	Group bypass entered	Group bypass in some partition
Blink slowly	8 seconds after Armed with Group Bypass	8 seconds after Armed with Group Bypass

Fire LED-Red	AV-2016	AV-2016DP
Blink slow	Warning before Fire alarm	Warning before Fire alarm
Blink fast	During and after Fire alarm	During and after Fire alarm

Note: Troubled Zones during alarm displayed at the Keypad.

○ **Red ARMED/ALARM Indicator** - Lights up when system is armed, and blinks after an alarm is triggered at any zone. Blinking indicates alarm history in memory.

○ **Green STATUS Indicator** – The Green LED Blinks when zone/s are troubled and remains lit as long as zones are clear, rapid blinking during Tamper alarm.

○ **Yellow SHUNT (Bypass) Indicator** - Lights up upon zone bypass.

(Note: may light automatically upon arming if Auto Bypass was programmed).

The indicator also lights up and blinks if a Group Bypass was entered by pressing '0' twice.

○ **Red FIRE (Trouble) Indicator** - Rapid blinking when a Fire Zone is troubled.

○○ **Two LEDs Flashing (Left Most LEDs)** - In user code programming mode, rapid blinking indicates code or code index to be entered. In Installer programming mode, it indicates address entry.

In Disarmed mode, the two left-most LEDs blinking + zone number display indicate 24H-alarm mode.

○○○ Three LEDs Flashing - In Disarmed mode, rapid blinking indicates AC power failure. AC power fail event is displayed in Events History as three lines ≡. Starting version 2.11 the LEDs will blink for six seconds every minute (energy saving).

In Armed mode, rapid blinking indicates system restored after AC Power Failure mode.

During programming Follow-Me Telephone Number, three flashing LEDs indicate to enter a new telephone number.

○○○○ Four LEDs Flashing - Upon holding-down key '8,' the system is ready for code to be entered. (Same LED indication when code is expected for Bypass via code.)

1.5 □ Keypad Digital Display (7-segment type)

The 7-segment display provides visual readout of system status. The display indicates zones in alarm, troubled zones, bypassed zones, and also displays the following confirmation letters:

Display	Description	Function
A	<i>Auto Arm</i>	'A' confirms that auto arming starts within 30 sec's
CA	<i>Up & Download</i>	'CA' displayed after 'Answer Now' selected
C	<i>Communication</i>	Tests dialer, and displays telephone numbers upon holding-down key 6
C	<i>Communication</i>	Flashing 'C' in display indicates telephone line trouble
c	<i>Chime</i>	Upon entering Chime mode via key 5, 'c' confirms Chime mode
c	<i>Closing</i>	Indicates system closing (Arming) followed by user number when events log is displayed
d	<i>Delay Delete or DTMF</i>	Upon holding-down key 4, to operate Delay Delete of delayed and follower zones. Indicate DTMF mode too
P	<i>Dial Delay</i>	When programming telephone numbers which require an inter-digit delay ('Pause') during dialing. (Delay duration is 2 seconds.)
E	<i>Error</i>	Indicates programming error
h	<i>Home</i>	Indicates entering of Group Bypass
h	<i>Hour</i>	Displayed after power-up to remind installer to set the system time; 'h' will be removed after time setting (using keys 0 and 1).
H	<i>Hold-Up</i>	Upon Panic triggering from Keypad, or upon activation of any other panic switch connected to the keypad
o	<i>Opening</i>	Indicates system opening (Disarming). Followed by user number when events log is displayed
L	<i>Low Battery</i>	Low battery indicated upon system arming, or during Disarmed mode
P	<i>Program</i>	System is in programming mode
t	<i>Tamper</i>	Indicates zone's Tamper alarm

U	<i>Update</i>	Confirms programming updating
u	<i>User</i>	'u' (user) followed by user number when events log is displayed and system is in user code programming mode
≡	<i>Arming Denied</i> or <i>AC Fail</i>	≡ displayed upon Arming attempt with non-delayed (instant) zones in trouble. ≡ displayed upon and after AC fail while system is Armed or Disarmed

1.6 □ Arm and Disarm System via AV-701/702 Series Keypad

1. Make sure that all burglary zones are closed.
2. The green Status LED indicator will remain lit (not blinking) while all zones are closed.
3. Green indicator will blink when a zone is troubled. Press key 3 for display of troubled zone on keypad. An open delayed zone (exit zone) will also cause indicator to blink.
≡ (3 lines) indicated at arming of system if instant zones or 24-Hour zones are troubled (blinking Green LED indicator followed by ≡ in display and 5 warning beeps); open zones will then be displayed.
4. To bypass a zone, press key 0 (Bypass Key), followed by the zone number.
To bypass a pre-programmed group of zones (requires programming), press 0 (zero key) twice (short press). AV-2016DP/2.09: Enter your code then press key 3.
5. Arming: Enter the Arm/Disarm code (No. 1 default code is 1,2,3,4), the Red Armed indicator will light up. If any zone (not Delayed or Follower) is troubled, ≡ will be displayed and system will remain Disarmed.
System Arming is disabled if Instant zone troubled.
6. For Instant Arming, press key 5 (if previously programmed). See address 071.
Red 'Armed' indicator should light up. The system is now armed.
7. Disarming: you may have to hold-down key 9 (reset) to clear any previous key presses, and then enter arm/disarm code (or turn optional key-switch); the Red 'Armed' indicator will go off.
Alarm history displayed upon disarming. If a 24H alarm occurs during Disarm mode Enter Arm/Disarm code.
8. **Keypad Keys Self Locking:** In Armed and Disarmed mode, after six attempts to enter fault code, the keys will not react to any key press. This prevents code learning or other code break exigency. After a 30 seconds delay, the keys will revert to code entry mode. Each new erroneous code will lock system for another 30 seconds.
9. **Auto Arming**
Programming the time for Automatic Arming:
- **By Installer:** Program (or display) the hours and minutes at address 016.
- **By User:** Enter to user programming mode. Hold down '8' ('A' is displayed); type hour and minutes in 24 hours format. To display, hold down '8' and wait. To disable Automatic Arming program 0000.

After Automatic Arming is programmed, the system time can be set only via User Programming Mode: Enter User Programming Mode (hold-down 8 and 1234), hold down '1' ('t' is displayed) and type hour and minutes. Hold down key '1' and wait for the time display. Holding down keys '0' then '1' (in use mode) to program the time is possible only if the Automatic Arming is disabled (otherwise an 'Error' warning is displayed). Those settings procedure at PRO panels is different; refer to the AV-706/7 keypad manual.

Automatic Arming will not operate if the system time has not been set (blinking 'h'). Automatic Arming will not operate if the control panel is already armed.

Automatic Arming will operate even if the control panel is currently in alarm.

When the Automatic Arming programmed time arrives, the system starts at a 30-second countdown. An 'A' is intermittently displayed and beeps are sounded at the keypad.

During the countdown period, to abort Automatic Arming enter a valid user code (not code No. 7, if used to 'open' a door).

SECTION IV: PROGRAMMING

1. SYSTEM CODES

Up to sixteen different Arm/Disarm codes and one installer (dealer) code are available; each code consists of 1 to 6 digits.

Do not use '0' as the first digit in a code.

Do not use '5' as first digit in a code number if *Instant Arming via key 5* was programmed.

User code must not start with the same numbers as the installer programming code (1994).

Do not use same codes or same first digit for different codes. For example if code No. 1 is 1234, programming code No. 2 cannot be 1256.

1. **Default Arming and Disarming Code '1 2 3 4'** (Code No. 1) - Use '1234' as Arming Code (also called Owner Code). Use code No. 1 to program a new user code.

Upon setting new Arming & Disarming code, default user code '1234' automatically replaced.

For setting default codes, Power up by applying AC and battery and immediately (during 20 seconds) hold-down keys Press both together after 2nd beep, release keys, 'U' displayed three times in confirmation. To set codes to default during programming; in address, 200 enter 05, all codes will restore to default.

2. **Code number 7 for access control** (requires programming) - Arm/Disarm code No. 7 activates the SLO (Selective Output) output, which is used for such functions as opening an electric lock.
Code number 7 is operative during ARM and DISARM modes, confirmed by seven short beeps. Code 7 drives the SLO output as 'Momentary' output.
Pulse duration is 5 seconds.
3. **Code number 8 as Visitor Code** (requires programming) - Arm/Disarm code No. 8 is for 'one time code' (employees and one-time visitors). This code is valid for 30 seconds from Arming. After 30 seconds, the code is rendered as invalid.
Entering code 8 will delete zone bypasses, including auto-bypass.
4. **Code number '9', Programming Code (Installer Code)** - Code No. 9 enables entering the programming mode (system features programming) at the Installer level.
The factory default programming code is '1 9 9 4.'
The programming code may be installer-programmed. Installer code does not Arm or Disarm system.
5. **User Codes** - (Arming and Disarming code). Each code consists of 1 to 6 digits. System provides eight user programmable codes.
6. **Key Visual Feedback** - Visual 'feedback' from the keypad display upon entering of code. This feature indicates the code entry progress and is most practical when the keypad buzzer is disabled at Group Bypass mode, or if selected by programming. Entry of code by user or installer is confirmed at keypad display. Display segments will light up clockwise, indicating the sequence of the digits entered.

Typing six erroneous codes will lock the keypad keys for 30 seconds

1.1 User Code Programming via AV-701 Keypad (Not with AV-2016DP)

Set New USER-CODE

1. Hold down key 
2. While the four LEDs are blinking, enter code No. 1 (default 1 2 3 4)
3. If code is valid, the four LEDs stop blinking, and ‘u’ displayed
4. The 2 left-most LEDs blink to indicate that the system is waiting for a new user code index (user 1 to 16) to be entered
5. Enter the code index (01 for code No. 1; 02 for code No. 2, etc.)
6. The 2 right-most LEDs blink to indicate that the system is waiting for a new code (1 to 6 digits) to be entered. **The code voided if user code not entered.**
7. Enter the new code; ‘U’ is displayed for confirmation.
8. To quit code setting hold-down key ‘9’.

Set new USER-CODE in Installer program mode

1. While system is in program mode, enter address 099, ‘u’ is displayed
2. The two left-most LEDs blink to indicate that the system is waiting for a new user code index (user 01 to 16) to be entered. User index displayed for 2 seconds, until user can press and enter further digits (eliminate confusing of index number and code)
3. The two right-most LEDs blink to indicate that the system is waiting for a new code (1 to 6 digits) to be entered. Enter the new code.
4. Installer Code (code no. 17) can only be set at Program mode. Installer Code index number is ‘17’.
5. Upon completion of code setting, system reverts to Disarm mode.

Delete a USER-CODE

1. Hold down key 
2. While four LEDs are blinking, enter code No. 1 (default 1 2 3 4)
3. If code is valid, four LEDs will stop blinking and ‘u’ display
4. The two left-most LEDs blink to indicate that the system is waiting for a new user code-index (01 to 16) to be entered.
5. Enter the code index you want to delete (1 for code No. 1; 2 for code No. 2, etc.)
6. The two right-most LEDs blink to indicate that the system is waiting for a new code.
If not entering a user code, the code voided. A short sounder beep confirms that code deleted
7. It is now possible to enter a new code; ‘U’ displayed for confirmation.
8. To quit code setting Hold-down key ‘9’.

Instant Arming by key number  is a programmable feature, which may cause erroneous Arming. It is recommended to *disable this feature*. Do not to use 5 or 0 as the 1st digit of the code

2. FEATURE PROGRAMMING AT INSTALLER LEVEL

2.1 □ Programming Table AV-2055D, 2088D, 2016D, 2016DP (V3.05)

1) ZONE 1 to 16 FEATURES

Zone Number →		1	2	3	4	5	6	7	8		9	10	11	12	13	14	15	16
Feature ↓	Add.	Group 1								Add.	Group 2							
Zone In Use	100	1	2	3	4	5	6	7	8	101	1	2	3	4	5	6	7	8
Entry/Exit Delay 1	104	1								105								
Entry/Exit Delay 2	108									109								
Entry / Exit Follower	112		2							113								
24-Hour Zone	116									117								
Fire zone	120									121								
Day Zone	124									125								
Green Zone	128	1	2	3	4	5	6	7	8	129	1	2	3	4	5	6	7	8
Swinger Shut-Down	132									133								
Chime	136	1								137								
EOL Resistor Zone	140									141								
Enable Tamper Zone	144									145								
Delayed Power-Up	148									149								
Fast Response	152									153								
Group Bypass 1	156									157								
Group Bypass 2/ Auto Bypas	160									161								
Manual Bypass	164	1	2	3	4	5	6	7	8	165	1	2	3	4	5	6	7	8
Siren Out	168	1	2	3	4	5	6	7	8	169	1	2	3	4	5	6	7	8
Alarm 1 Output	172	1	2	3	4	5	6	7	8	173	1	2	3	4	5	6	7	8
Alarm 2 Output	176									177								
SLO output ²	180									181								
Dial on Alarm	184	1	2	3	4	5	6	7	8	185	1	2	3	4	5	6	7	8
Keypad sounder on Alarm	188	1	2	3	4	5	6	7	8	189	1	2	3	4	5	6	7	8
Normally Open (N.O.)	192									193								
Panic Zone	196									197								

In AV-2016DP: Addresses 160 and 161 are “Automatic Bypass” (not “Group Bypass 2”)

ZONE 17 to 32 FEATURES

Zone Number →		17	18	19	20	21	22	23	24		25	26	27	28	29	30	31	32
Feature ↓	Add.	Group 3								Add.	Group 4							
Zone In Use	102									103								
Entry/Exit Delay 1	106									107								
Entry/Exit Delay 2	110									111								
Entry / Exit Follower	114									115								
24-Hour Zone	118									119								
Fire zone	122									123								
Day Zone	126									127								
Green Zone	130	1	2	3	4	5	6	7	8	131	1	2	3	4	5	6	7	8
Swinger Shut-Down	134									135								
Chime	138									139								
EOL Resistor Zone	142									143								
Enable Tamper Zone	146									147								
Delayed Power-Up	150									151								
Fast Response	154									155								
Group Bypass 1	158									159								
Group Bypass 2	162									163								
Manual Bypass	166	1	2	3	4	5	6	7	8	167	1	2	3	4	5	6	7	8
Siren Out	170	1	2	3	4	5	6	7	8	171	1	2	3	4	5	6	7	8
Alarm 1 Output	174	1	2	3	4	5	6	7	8	175	1	2	3	4	5	6	7	8
Alarm 2 Output	178									179								
SLO output ²	182									183								
Dial on Alarm	186	1	2	3	4	5	6	7	8	187	1	2	3	4	5	6	7	8
Keypad sounder on Alarm	190	1	2	3	4	5	6	7	8	191	1	2	3	4	5	6	7	8
Normally Open (N.O.)	194									195								
Panic Zone	198									199								

² SLO is a non-timed output. SLO = Selective output.

Factory Default Program is as shown in table; Blank Square means no default program

2) TELEPHONES, SIGNAL TEST TIME

Tel. 1	Tel. 2	Tel. 3	Tel. 4
010	011	012	013

Address >	Test Signal Time	Auto Arm Time
Time >	014	016
	(00:01)	00:00

Tel. 1 is 'Follow Me'. Tel. 2 and 3 are communicator option. Tel. 4 is Dialer.
(According to programming). Maximum 16 digits + 4 pauses each Tel. Number.

Test signal to central station. Codes define at address. 237 & 255. Enter time in 24 hour format

NB: Press and hold the '9' key until the keypad beeps, after the address to erase telephone numbers.

To insert * in the phone number: Enter to program mode, program system to dial in DTMF, Hold-down keys # and * (as panic), 'A' will be displayed.
To enter Pause during dialing hold-down key '0'.

3) OUTPUTS and TIME-OUTS

Entry Delay 1		Entry Delay 2		Exit Delay		Siren Time		ON Siren Time		OFF Siren Time		A1 Time		A2 Time		Chime Time		Abort Delay	
Sec's		Sec's x 4		Sec's x 4		Minutes		Sec's		Sec's		Sec's		Minutes		Beeps		Sec's	
060		061		062		063		064		065		066		067		068		069	
1	2	0	0	0	8	0	4	1	5	0	4	3	0	0	4	0	3	0	0

4) SYSTEM FEATURES

Feature	070
Enable-Siren/Bell Test upon Arming	1
Enable-3 Beeps upon Disarming	(2)
Enable-Buzzer upon Entry Delay	(3)
Enable-Keypad Tactile Beep	(4)
Disable-4 LEDs display during Armed	5
Enable-Battery Test upon Arming	(6)
Enable-Code No. 7 for Access Control ¹	7
Enable-Keypad Panic	(8)

Feature	071
Enable-Erase F. Me number on Disarm	1
Enable-Instant Arming via Key 5	2
Enable-SLO 1 as reset for smoke detector	3
Enable-Display Troubled/Open Zone	4
Enable-Manual Bypass via Code No. 1	5
Lock in Armed after Tamper Alarm	6
Enable-Momentary Key-Switch	(7)
Enable-Code '8' as one time code	8

Feature	072
Enable-Bell mode	(1)
Enable-Detailed alarm history	(2)
Enable-Report Opening/Closing	(3)
Activate ON output for ADSL filter line-cut	4
Enable-Report bypassed zones at Arming	5
Enable-Exit delay when delayed zones clear	6
Enable -'ON' output as SVM trigger	7
Enable -Codes reset to default by hold *& #	(8)

Feature	073
Enable-Display troubled zones at Disarmed	1
Enable-Test to central station each hour	2
Enable-Self contain Bell (0V at alarm) **	3
Enable-Buzzer upon exit delay	4
Enable- Group Bypass when Armed by Key	5
Enable- 2 Siren Beeps at Disarming by Key	6
Enable-A1 Output active during siren time	(7)
Enable - Inverting of Outputs polarity	8

Keypad Panic Alarm	074
Enable-Siren on Panic	1
Enable-Alarm 1 On Panic	2
Enable-Alarm 2 On Panic	3
Enable-SLO On Panic	(4)
Enable-Telephone Report	(5)
Enable-Buzzer alarm on Panic	6
Enable-Enable Emergency Buttons	7
Enable- Double Zone (AV-2055,2088 only)	8

Tamper Alarm	075
Enable-Tamper zone 24H zone	1
Enable-Alarm 1 on Tamper	2
Enable-Alarm 2 on Tamper (not at 2055,88)	3
Enable-SLO on Tamper	4
Enable-Last zone as KEY (from V 3.05)	5
Enable-Tel. Line test at Disarm Mode	6
Enable-Activate SLO at Tel. Line fail	7
Enable-Dialer reports on AC fail	8

Feature	076
Enable -'SLO1' output for SVM trigger	1
Enable - Remote A1 activation by DTMF	2
Enable - Auto Reset before alarm time out	3
Enable - Alarm panel DTMF control	(4)
Enable - Sounder for Tel. line fault	5
Enable - Siren for tel. line fault	6
Enable - Bypass Answering Machine	7
Enable-Echo Cancellation Tone (AUSTEL)	8

¹ - Code No. 7 for access control drives SLO 1 output ** Self-contained Bell is operative if Bell mode selected

*** Available in AV-2055, 2088, 2016 (not in 'P' version). **In Australia, program '8' in address 076.**

* Those features cannot be enabled at the same time.

Address 077, CS test day: 1 - Sun 2 - Mon, 3 - Tues, 4 - Wed., 5 - Thu., 6 - Fri., 7 - Sat., 8 - All week's days, 0 - Clear all

5) DIAL AND MODEM PARAMETERS

Pre-Dial Delay	Wait for Dial Tone	Anti-Jam Delay	Dial tone detection	Dial Mode	Tel. MSG Time	Inter-Call Delay	Re-Dial Cycles (max.)	Pulse Make	Pulse Break	Inter Digit Delay	Rings qu'ty for modem	Instant mode m answer
Sec's	Sec's	Sec's	00 = No 01 = Yes	0= Pulses 1= DTMF	Sec's	Sec's	XX Cycle	5 mS	5 mS	50 mS	Tel. Rings	00 = No 01 = Yes
080	081	082	083	084	085	086	087	088	089	090	091	092
0 2	0 4	1 0	0 1	0 1	5 0	2 0	0 3	0 8	1 2	2 0	1 0	0 1

Rings before Answer	Answer Now (Modem)	DTMF Length	Min. Ring Length	Min. Ring Cycle	Tel. Line Test Intervals	Ring Time out
Rings	00 = No 01 = Yes	5 m'S	10 m'S (10-20)	100 m'S (7-25)	Minutes (Max 99)	Seconds (4-35)
091	092	093	094	095	096	097
1 0	0 1	1 9	1 5	1 5	0 0	0 6

Note address 091: The download is ENABLED by default. Enter a value of 21 at address 091 to disable modem (21 rings for modem not accepted by telephone net). To ENABLE enter 01 to 20 at address 091. To enable Instant Modem Answer function (Answer Now), hold-down key 6 then hold-down key 1. 'A' displayed in confirmation.

6) USER CODES SETTING Address 099 provides setting of user codes 01 to 17

099								
USER 01	USER 02	USER 03	USER 04	USER 05	USER 06	USER 07	USER 08	Installer Code
1,2,3,4								
USER 09	USER 10	USER 11	USER 12	USER 13	USER 14	USER 15	USER 16	USER 17
								1,9,4

For programming End-User codes 1 to 17 (Arm/Disarm & Programming codes) via installer programming mode; enter to address No. 099, then program new codes by first entering the code index (01, 02, 03...). User 1 code is the Master code (for changing codes), user 17 code is the programming code - If changed code 1 or 17 make a note of the new codes. To erase a code does not enter any digit after the code index number. To send the Force Opening Code (Ambush) the user should enter the Disarming code in reverse order.

7) FACTORY DEFAULT SETTING: Enter 6 9 in address 200, to revert to factory default programming

8) COMMUNICATOR PARAMETERS

TELEPHONE	Receiver Format	Handshake Frequency	Data Format	Protocol Type	Check Sum (Parity)	Transmit Rounds	Inter Rnd Delay	Wait for Handshake
No. 2	021	023	025	027	029	031	033	035
	0 0	0 2	0 0	0 0	0 0	0 0	3 0	2 0

TELEPHONE	Receiver Format	Handshake Frequency	Data Format	Protocol Type	Sum Check (Parity)	Transmit Rounds	Inter Rnd Delay	Wait for Handshake
No. 3	022	024	026	028	030	032	034	036
	0 0	0 2	0 0	0 0	0 0	0 0	3 0	2 0

00 - Dialer only (No Communicator)	00=1400 Hz	00=3 X 1	00=Standard	00=None	00=2 Rnd	00=0.1 Sec	XX=Sec's
01 - Ademco, Silent Knight Slow, Scantronic	01=2300 Hz	01=4 X 1	01=Extend	01=S. Check	01=1 Rnd	30=3 Sec	
02 - Radionics Fast							
03 - Sescoa, Vertex, DCI, Franklin	02=Hi/Low	02=4 X 2				3 Sec's is Default	
04 - Silent Knight Fast							
05 - Radionics, DCI, Franklin Slow	02=Hi/Low	03=3 X 2					
06 - Universal High Speed	**						
07 - Contact ID/Ademco Fast*							

00 - 'No Communicator,' is identical to 'Dialer' that generates sound upon alarm. ** For Contact ID, program 07 in 021 & 022 address.

* For Ademco Fast Receiver type 685 enter 02 at address 023 & 024.

9) COMMUNICATOR, REPORT SELECTION. By factory default all zones selected to be reported. Sections 9 and 10 require no programming if Contact ID selected.

Group 1									Group 2							
Report on Alarm, zone 1-8 Address 040									Report on Alarm, zone 9-16 Address 041							
1	2	3	4	5	6	7	8	<<ZONE>	9	10	11	12	13	14	15	16
1	2	3	4	5	6	7	8	<<VALUE>	1	2	3	4	5	6	7	8

Group 3									Group 4								Group 5		
Report on Alarm zone 17-24 Address 042									Report on Alarm zone 25-32 Address 043								Trouble 044		
17	18	19	20	21	22	23	24	<<ZONE>	25	26	27	28	29	30	31	32	AC	LB	PA
1	2	3	4	5	6	7	8	<<VALUE>	1	2	3	4	5	6	7	8	1	2	3

Group 1									Group 2							
Report on Zone Restore, zone 1-8 Address 045									Report on Zone Restore, zone 9-16 Address 046							
1	2	3	4	5	6	7	8	<<ZONE>	9	10	11	12	13	14	15	16
1	2	3	4	5	6	7	8	<<VALUE>	1	2	3	4	5	6	7	8

Group 3									Group 4								Group 5		
Report on Zone Restore, zone 17-24 Address 047									Report on Zone Restore, zone 25-32 Address 048								Trouble 049		
17	18	19	20	21	22	23	24	<<ZONE>	25	26	27	28	29	30	31	32	AC	LB	PA
1	2	3	4	5	6	7	8	<<VALUE>	1	2	3	4	5	6	7	8	1	2	

Group 1									Group 2							
Report on Zone Bypass, zone 1-8 Address 050									Report on Zone Bypass, zone 9-16 Address 051							
1	2	3	4	5	6	7	8	<<ZONE>	9	10	11	12	13	14	15	16
1	2	3	4	5	6	7	8	<<VALUE>	1	2	3	4	5	6	7	8

Group 3									Group 4							
Report on Zone Bypass zone 17-24 052									Report on Zone Bypass zone 25-32 053							
17	18	19	20	21	22	23	24	<<ZONE>	25	26	27	28	29	30	31	32
1	2	3	4	5	6	7	8	<<VALUE>	1	2	3	4	5	6	7	8

Display version: The version (revision) and its date can be displayed in installer programming mode by command 200+00

10) Communicator Codes - For ALARM, RESTORE, BYPASSED ZONES, OPENING / CLOSING, SIGNAL TEST & FORCE OPENING. The codes appear in 1st DIGIT CODE and in 2nd DIGIT CODE are programmed by factory. (Sections 9 and 10 require no programming if Contact ID selected)

For communicator codes A to F, enter the following: A=10, B=11, C=12, D=13, E=14, F=15. Note: entering 0 0, is equal to blank.

Group 1									Group 2							
Alarm Codes Zone 1-8									Alarm Codes Zone 9-16							
1	2	3	4	5	6	7	8	<<ZONE>>	9	10	11	12	13	14	15	16
201	203	205	207	209	211	213	215	<<ADDRESS>>	217	219	221	223	225	227	229	231
3	3	3	3	3	3	3	3	<1st DIGIT CODE>	3	3	3	3	3	3	3	3
202	204	206	208	210	212	214	216	<<ADDRESS>>	218	220	222	224	226	228	230	232
1	2	3	4	5	6	7	8	<2nd DIGIT CODE>	1	2	3	4	5	6	7	8

Group 3									Group 4								Group 5		
Alarm Codes - Codes Zone 17-24									Alarm Codes - Codes Zone 25-32								Panel Trouble		
17	18	19	20	21	22	23	24	<<ZONE>>	25	26	27	28	29	30	31	32	AC	LB	PA
233	235	237	239	241	243	245	247	<<ADDRESS>>	249	251	253	255	257	259	261	263	265	267	269
3	3	3	3	3	3	3	3	<1st DIGIT CODE>	3	3	3	3	3	3	3	3	F	F	2
234	236	238	240	242	244	246	248	<<ADDRESS>>	250	252	254	256	258	260	262	264	266	268	270
1	2	3	4	5	6	7	8	<2nd DIGIT CODE>	1	2	3	4	5	6	7	8	9	8	1

Group 1									Group 2							
Zone Restore - Codes Zone 1-8									Zone Restore - Codes Zone 9-16							
1	2	3	4	5	6	7	8	<<ZONE>>	9	10	11	12	13	14	15	16
281	283	285	287	289	291	293	295	<<ADDRESS>>	297	299	301	303	305	307	309	311
E	E	E	E	E	E	E	E	<1st DIGIT CODE>	E	E	E	E	E	E	E	E
282	284	286	288	290	292	294	296	<<ADDRESS>>	298	300	302	304	306	308	310	312
1	2	3	4	5	6	7	8	<2nd DIGIT CODE>	1	2	3	4	5	6	7	8

Group 3									Group 4								Group 5		
Zone Restore - Codes Zone 17-24									Zone Restore - Codes Zone 25-32								Control Panel Restore		
17	18	19	20	21	22	23	24	<<ZONE>>	25	26	27	28	29	30	31	32	AC	LB	PA
313	315	317	319	321	323	325	327	<<ADDRESS>>	329	331	333	335	337	339	341	343	345	347	349
E	E	E	E	E	E	E	E	<1st DIGIT CODE>	E	E	E	E	E	E	E	E	E	E	E
314	316	318	320	322	324	326	328	<<ADDRESS>>	330	332	334	336	338	340	342	344	346	348	350
1	2	3	4	5	6	7	8	<2nd DIGIT CODE>	1	2	3	4	5	6	7	8	9	B	A

Group 1									Group 2							
Zone Bypassed - Codes Zone 1-8									Zone Bypassed - Codes Zone 9-16							
1	2	3	4	5	6	7	8	<ZONE>	9	10	11	12	13	14	15	16
361	363	365	367	369	371	373	375	<ADDRESS>	377	379	381	383	385	387	389	391
8	8	8	8	8	8	8	8	<1st DIGIT CODE>	8	8	8	8	8	8	8	8
362	364	366	368	370	372	374	376	<ADDRESS>	378	380	382	384	386	388	390	392
1	2	3	4	5	6	7	8	<2nd DIGIT CODE>	1	2	3	4	5	6	7	8

Group 3									Group 4							
Zone Bypassed - Codes Zone 17-24									Zone Bypassed - Codes Zone 25-32							
17	18	19	20	21	22	23	24	<ZONE>	25	26	27	28	29	30	31	32
393	395	397	399	401	403	405	407	<ADDRESS>	409	411	413	415	417	419	421	423
8	8	8	8	8	8	8	8	<1st DIGIT CODE>	8	8	8	8	8	8	8	8
394	396	398	400	402	404	406	408	<ADDRESS>	410	412	414	416	418	420	422	424
1	2	3	4	5	6	7	8	<2nd DIGIT CODE>	1	2	3	4	5	6	7	8

Group 1									Group 2								
Closing (Arming) - Codes User 1-8									Closing (Arming) - Codes User 9-16								Test Signal
1	2	3	4	5	6	7	8	<USER>	9	10	11	12	13	14	15	16	Test
430	432	434	436	438	440	442	444	<ADDRESS>	446	448	450	452	454	456	458	460	494
C	C	C	C	C	C	C	C	<1st DIGIT CODE>	C	C	C	C	C	C	C	C	A
431	433	435	437	439	441	443	445	<ADDRESS>	447	449	451	453	455	457	459	461	495
1	2	3	4	5	6	7	8	<2nd DIGIT CODE>	1	2	3	4	5	6	7	8	9

Group 1									Group 2									
Opening (Disarming) - Codes User 1-8									Opening (Disarming) - Codes User 9-16								Test Signal	Forced Opening
1	2	3	4	5	6	7	8	<USER>	9	10	11	12	13	14	15	16	Test	F. Open
462	464	466	468	470	472	474	476	<ADDRESS>	478	480	482	484	486	488	490	492	496	498
B	B	B	B	B	B	B	B	<1st DIGIT CODE>	B	B	B	B	B	B	B	B	D	0
463	465	467	469	471	473	475	477	<ADDRESS>	479	481	483	485	487	489	491	493	497	499
1	2	3	4	5	6	7	8	<2nd DIGIT CODE>	1	2	3	4	5	6	7	8	9	2

In order to disable reporting of Closing/Opening, change program at address 072; remove value '3.' When SIGNAL TEST is enabled, you can specify System Status report by programming 'Armed' and 'Disarmed.' For example 'A' (Armed) at 236, and 'D' (Disarmed) at 254, '9' is the test signal code. For System Status report, select extended or 2-digit format.

11) SELECT ZONES FOR PARTITION (Partition No. 01 is by default zone 1 to 32)

Zone Number →		1	2	3	4	5	6	7	8		9	10	11	12	13	14	15	16
Partition ↓	Add.	Group 1								Add.	Group 2							
Partition 01	500	1	2	3	4	5	6	7	8	501	1	2	3	4	5	6	7	8
Partition 02	504									505								
Partition 03	508									509								
Partition 04	512									513								
Partition 05	516									517								
Partition 06	520									521								
Partition 07	524									525								
Partition 08	528									529								

Zone Number →		17	18	19	20	21	22	23	24		25	26	27	28	29	30	31	32
Partition ↓	Add.	Group 1								Add.	Group 2							
Partition 01	502	1	2	3	4	5	6	7	8	503	1	2	3	4	5	6	7	8
Partition 02	506									507								
Partition 03	510									511								
Partition 04	514									515								
Partition 05	518									519								
Partition 06	522									523								
Partition 07	526									527								
Partition 08	530									531								

12) SELECT USERS FOR EACH PARTITION.

Maximum 8 partitions. (By default Users 01 to 16 are linked Partition No. 01). Partition number should be entered in two (2) digits.

Group 1								Group 2								
Partition User 1-8								Partition User 9-16								
1	2	3	4	5	6	7	8	<USER>	9	10	11	12	13	14	15	16
-	533	534	535	536	537	538	539	<ADDRESS>	540	541	542	543	544	545	546	547
-	01	01	01	01	01	01	01	<PARTITION >	01	01	01	01	01	01	01	01

UNDER BUILDING ON 13) AUTOMATIC ARM AND DISARM TIMERS

AUTO ARM & DISARM CYCLE	Auto Arm Time	Enable = 01 Disabled = 00	Auto Disarm Time	Enable = 01 Disabled = 00	Partition Number
Cycle 1	(00:01)	00	(00:01)	00	01
Address	550	582	566	590	598
Cycle 2	(00:01)	00	(00:01)	00	01
Address	552	583	568	591	599
Cycle 3	(00:01)	00	(00:01)	00	01
Address	554	584	570	592	600
Cycle 4	(00:01)	00	(00:01)	00	01
Address	556	585	572	593	601
Cycle 5	(00:01)	00	(00:01)	00	01
Address	558	586	574	594	602
Cycle 6	(00:01)	00	(00:01)	00	01
Address	560	587	578	595	603
Cycle 7	(00:01)	00	(00:01)	00	01
Address	562	588	574	596	604
Cycle 8	(00:01)	00	(00:01)	00	01
Address	564	588	580	597	605

Enter time in 24-hour format.

14) TEL. 2 COMMUNICATOR - SUBSCRIBER ID CODES

Note: For subscriber ID that contains a '0' (zero), enter 10 in place of 0. '0' will be displayed as 'A.' Do not enter 0 0.

Group 1				Group 2				Group 3				Group 4				Group 5				Users 1-9				Users 9-16			
Alarm / Restore ID				Alarm / Restore ID				Alarm / Restore ID				Alarm / Restore ID				Alarm / Restore ID				Opening/Closing ID				Opening/Closing ID			
610	611	612	613	618	619	620	621	626	627	628	629	634	635	636	637	642	643	644	645	650	651	652	653	658	659	660	661

EASY PROGRAMMING - TEL. 2 COMMUNICATOR - SUBSCRIBER ID CODES

Group 1				Group 2				Group 3				Group 4				Group 5				Users 1-9				Users 9-16			
EASY Program				EASY Program				EASY Program				EASY Program				EASY Program				EASY Program							
Alarm / Restore ID				Alarm / Restore ID				Alarm / Restore ID				Alarm / Restore ID				Alarm / Restore ID				Open. / Closing ID				Open. / Closing ID			
710				718				726				734				742				750				758			

To program the subscriber ID number more easily (as a sequence of 4 digits), use the EASY Program (available only from VER 1.04 and up). Even if your code is only three digits, you must still enter four digits. The 4th digit can be any digit, and the system will disregard the 4th digit.

TEL. 3 COMMUNICATOR - SUBSCRIBER ID CODES

Group 1				Group 2				Group 3				Group 4				Group 5				Users 1-9				Users 9-16			
Alarm / Restore ID				Alarm / Restore ID				Alarm / Restore ID				Alarm / Restore ID				Alarm / Restore ID				Opening/Closing ID				Opening/Closing ID			
614	615	616	617	622	623	624	625	630	631	632	633	638	639	640	641	646	647	648	649	654	655	656	657	662	663	664	665

EASY PROGRAMMING - TEL. 3 COMMUNICATOR - SUBSCRIBER ID CODES

Group 1				Group 2				Group 3				Group 4				Group 5				Users 1-9				Users 9-16			
EASY Program				EASY Program				EASY Program				EASY Program				EASY Program				EASY Program							
Alarm / Restore ID				Alarm / Restore ID				Alarm / Restore ID				Alarm / Restore ID				Alarm / Restore ID				Open. / Closing ID				Open. / Closing ID			
714				722				730				738				746				754				762			

To program the subscriber ID number more easily (as a sequence of 4 digits), use the EASY Program (available only from VER 1.04 and up). Even if your code is only three digits, you must still enter four digits. The 4th digit can be any digit, and the system will disregard the 4th digit.

Values beneath addresses are default programming.

Address - a location on the programming sheet.

Addresses reside between 003 and 762.

Value - determines the characteristics of an address.

2.2 □ Introduction

- The program determines most of the control panel features. Programming is performed in order to enable maximum compatibility of the control panel with the specific site.
- The control panel is supplied with the basic 'Factory Default Program,' which is in effect at system power up. (See also: Factory defaults programming.). Factory default setting: Enter 6 9 in address 200, to revert to factory default programming
- Before starting programming, mark the desired values on the programming sheet.

2.3 □ Programming Sheet Explanation

Table 1: Enter the zone feature by zone number, as described in addresses 100 to 191.

Table 2: Addresses 010 to 013 used to enter the telephone numbers that dialed upon alarm or at other events (when communicator to central station been programmed).

Telephone numbers 2 & 3 are for communicator (if selected), or non-communicator, according to programming of addresses 021 & 022. Telephone numbers 1 & 4 are only for regular telephone dialer with sound alarm.

Table 3: Addresses 060 to 069 indicate the times out. Enter the time in two digits. (e.g. for two seconds, enter 0 and then 2).

Address 074 and 075 manage five different features that specify the alarm outputs upon Panic and Tamper alarm.

Note: entering a '0' value at address 074 or 075 will delete all four-alarm outputs during Panic or Tamper alarm at that address zone.

Table 4: Addresses 070 to 072 indicate special features of the system. Enter the required features by their number in each address. Each address contains 8 different parameters.

Table 5: Addresses 080 to 092 indicate telephone specifications according to local telephone company requirements. Address 091 and 092 sets the up and download modem.

Table 6: Address 099 provides setting of user codes 1 to 17 within the programming mode.

Table 7: Address 200 reverts system to factory default by entering 69. Entering 77 in address 200 sets the panel to local up and download mode.

Table 8: Addresses 021 to 036 sets the communicator parameters according to your central station's specifications. Contact the central station for full details.

Table 9: Addresses 040 to 054 provides selection of the required events to be reported. For example, to select zones 1,2 and 6 for Zone Restore report program 1,2 and 6 in address 045. Do not program if Contact ID format selected.

Table 10: Addresses 201 to 350 contains the codes that are reported for the selected events. The codes programmed as default factory default; you may change them according to your central station requirements. Do not program if Contact ID format selected.

Table 11: Addresses 500 to 531 provides to set the required zone for each partition. The default is zone 1-32 to be in partition No. 01.

Table 12: Addresses 532 to 547 provides to set the required users for each partition. The default is users 1 to 16 to Arm and Disarm partition No. 01.

Table 13: Addresses 550 to 605 the time set for each timer, and selects which partition will be Armed and Disarmed at this time. Each automatic Arming or Disarming can enabled or disabled.
NOT OPERATIVE YET (marked with cross lines)

Table 14: Addresses 619 to 762 contains the communicator Subscriber ID Code transmitted to the central station. Follow EASY program instructions for fast subscriber ID codes programming.

Programming Mode automatic timeout is three minutes for user programming mode and fifteen minutes for installer programming mode

2.4 □ Glossary of Programmable Features

Note! A zone not programmed as a 24H, Delayed, Fire or Follower zone, is automatically acknowledged as an Instant zone

24-Hour Zone - Zone programmed for 24-hours protection. Alarm sounded in both Armed and Disarmed modes, indicated by Armed LED blinking. If 24H zone remains troubled after disarming the system a warning buzzer will sound after 10 seconds (allows the user to repair or bypass the troubled zone) from disarming. After another 10 seconds, alarm is on.

Address: 116-119.

Abort Report (to CS) - If the system disarmed during the "abort delay" there will be no report to central station. Events during this period recorded in history. Address: 069

Answering Machine Bypass - In case the alarm panel is connected with fax or answering machine on the same line, this feature provide to connect to the control panel for up and download. If this feature is not enabled the fax or answering machine answers before the panel, connection is impossible. Program at least 20 seconds at address 097 (ring time out), Program 7 at address 076.

Auto Bypass Zone (effects only Instant Zone) - Starting version 2.16 this feature canceled.

Code '8' as One Time Code - This feature enables user code no. 8 as one time Arming code. When this feature selected, the code will be operative during 30 seconds after Arming with code 8. During the 30 seconds, Code No. 8 will be active for both Arming and Disarming. Enter '8' at address 071 to enable this feature.

Day Zone - A zone programmed as a Day Zone enables alarm from keypad's buzzer during daytime (system is usually disarmed). The day zone will trigger the keypad sounder and the zone number will flash on keypad display. To reset Day Zone alarm, hold-down key 9 (reset key).

During Arm mode, this zone will act as burglary zone and will sound an alarm when troubled.

Address: 124-127.

Delayed Zone - A zone programmed as a Delay Zone provides exit and entry delay time from moment of arming. See Entry Delay 1 and 2.

Dial Parameters - Enables adjustment of dialing specifications according to local requirements. The most critical are the Pulse Make and Pulse Break times (Pulse Dial mode), which may be different in each area. Steps are by 5 milliseconds (ms), which is sufficient according to tolerance requirements of +/- 2 milliseconds. Contact the local Telephone Company for full specifications in your area. Addresses: 080-096.

DTMF - Telephone signaling, used for remote control and activation of Av-Gad panels.

Enable Siren Test upon Arming - Short beep sound for siren test upon arming, indicating that the system armed and siren is OK. To enable this feature (Siren Test upon Arming), enter value '1' in address 070.

Enable SLO 1 for Smoke Detector Reset - After the smoke alarm is triggered, reset is required. Pressing key '9' activates SLO 1, which shortly disconnects smoke detector power (via optional relay) and resets automatically. Address: 071- 3.

Entry Delay 1 and 2 - To enable two different entry delay periods, program-selected zone(s) for Entry Delay 1, and other zones for Entry Delay 2. To cancel entry delay, hold - down key 4 before Arming.

Entry Delay 1 maximum delay time is 99 seconds, and Entry Delay 2, up to 396 seconds (see addresses 060 and 061).

Addresses: 104, 106, 108, 110.

Entry/Exit Follower Zone - Reacts instantly upon detection without previous triggering of delayed zone. Exit delay affects follower zones. Follower zone acts as delayed zone during exit delay and after entering via delayed zone. Try to avoid installing magnetic switches for protection of a follower zone. (Use magnetic switch in delayed zone only for entry/exit door).

Address: 112-115.

Erase 'Follow-Me' Number upon Disarming - After disarming the system, the Follow-Me number is deleted. If 'Erase' feature is not programmed, the 'Follow-Me' number will be stored in the system memory as the first Dialer number.

Address: 071-1.

Exit Delay - Determines the delay period (for delayed or follower zones) before zone becomes active. Countdown starts upon system arming. Maximum exit delay is 396 seconds.

Address: 062.

Exit Delay when Delayed Zones Clear - Enables system Arming only when all delayed zones are clear. Exit Delay will start the countdown. Applicable when long or variable exit delay is required.

Address: 072.

Fire Zone - Zone programmed for connection of fire or smoke detector. Alarm sounded in both Armed and Disarmed modes. Activate the Fire LED. If Fire zone remains troubled after disarming the system a warning buzzer will sound after 10 seconds from disarming (allows the user to repair or bypass the troubled zone). After another 10 seconds, the alarm is on.

The siren sounds different at 24H zone alarm (not same as burglary alarm).

Address: 120-123.

Fast Response Zone - Fast Response time of 100 ms (standard response time is 750 ms). Use Fast Response zone for connection of shock (inertia) or beam type detectors. The response time for zones programmed as 'fast Response' is not adjustable in AV-2016D/DP.

Note: Applicable for very short open time contacts. **Warning:** Fast Response zones increase the probability of false alarms. Addresses: 152-155.

‘Follow-Me’ Number - Telephone number programmed by user before Arming, enables user to program a telephone number that will call (follow) him at the locations he go to in case of alarm. Addresses: 010.

Forced Opening (Ambush) - Forced Opening (disarming) is operative only if ‘Report to Central Station’ is selected (refer to program table address 256). By disarming the system with the opposite sequence, code (arming with 1234 code, and disarming with 4321 code) the system will report a forced opening (forced Disarming).

Group Bypass (Home Mode) - Group Bypass enables removal of several zones from the system. The group of zones to be bypassed (shunt) is programmable. Refer to address 156-161, 158-163. To activated Group Bypass is press key ‘0’ twice before arming the system, and is effective only if system is armed within 20 seconds of ‘Group Bypass’ entry. Starting Version 2.13 there are two bypassed groups. Upon Group Bypass activation, the Yellow LED flashes, and ‘h’ (Home) is displayed for 1 second. Group Bypass via code is optional-refer to address 071, also see Section III.

Green Reset Zone - This feature disables zones in alarm to keep alarming as long as the zone is troubled. Useful in case of wire cut, broken sensor, etc. In such case, the zone will alarm one siren cycle and will alarm again only after zone cleared and troubled again.

Green Reset Zone required by the environment authorities to keep the alarm noise as short as possible. Zones programmed as a ‘Green Reset Zone,’ will not signal another alarm if the zones remain troubled.

Address: 128-131.

Inter Call Delay - Time delay until dialer proceeds to next telephone number.

Address: 086. (Recommended and default value: 20)

Instant Arming - For instant arming press key ‘5.’

It is recommended to disable this feature if keypad is too easily accessible.

Address: 071-2.

Keypad Sounder on Alarm - This feature enables keypad sounder during alarm. When alarm is on, a modulated tone will sound until disarming of the system.

Address: 188, 189, 190, 191.

Lock in Arm after Tamper Alarm - This feature will prevent Disarming when a Tamper alarm has occurred during Armed mode.

To Disarm system, enter Programming code (installer code) to unlock system, then enter a valid User Code.

To meet required standards, use this feature, which ensures that only the Installer (system engineer) can disarm a system in which Tamper alarm occurred while system was Armed. Example: Prevents ‘Self-Burglary’ by owner. Addresses: 071.

Manual Bypass (Manual Shunt) - Any zone (1 to 32), selected as Selective Bypass, maybe bypassed (removed from the system) by pressing key ‘0’ and then the zone number. The Yellow LED will light up in confirmation. It is not possible to bypass all zones. Upon Disarming, all bypassed zones will automatically become non-bypassed.

Zone Bypass Via Code (requires programming, see address 071) is optional.

Address: 164-167.

EOL Resistor Zone - Programmed zone(s), wired with an End of Line resistor, will be activated upon opening the loop between the zone and common (-).

Address: 140-143.

‘Off’ Siren Time - Determines silent period during an alarm cycle. This feature helps prevent over-heating of sirens and electronic components and prevent noise. Required against noise pollution by environmental authorities. (Recommended default value: 04).

Address: 065.

‘On’ Siren Time - Determines siren sounding period during the alarm cycle.

Programming a value of ‘0’ will render audible in all types of zones.

(Recommended and default value: 15).

Address: 064.

Outputs Deliver High at Alarm - If programmed during alarm, the A1, ON, SLO outputs will deliver High (drives Low when disabled) at alarm. This feature is most applicable for driving wireless central station RF transmitters or other devices requiring High (max. 100 mA) when triggered. If another feature is selected for the same output, this feature will be canceled.

Normally Open Zones – Zone defined as Normally Open cause alarm when the zone is connected to –V. The N.O. relay in alarm will cause a SHORT condition, which will trigger the alarm.

Sensor with Normally Open (N.O.) relay can be wired without EOL resistor. If several N.O. devices are used, wire them in parallel. If N.O. feature is not programmed, N.O. devices, such as push-button, should be wired in parallel to the EOL resistor.

Address: 192-195.

Programming Code (Code number 17) – The programming code provides access to the Installer Programming mode.

To program is possible if the current Programming Code is known.

Default programming code is ‘1 9 9 4.’

Power Fail Report to Dialer – If AC fail for certain time (address 058) the dialer sends alarm sound to the dialer. The alarm sound has unique sound (not as alarm sound). Address: 075-8.

Panic Alarm - Holding down * and # keys will trigger Keypad Panic alarm; H is displayed (zone 'H').

To reset the alarm enter a valid code. Panic Zone included at address 196-199, the default is 0.

The Panic zone provides to use remote panic buttons; in previous version, only Panic from keypad was available. When AV-707B keypad is interfaced Panic, Medical and fire button are included, to enable them program at 074 a 7.

Contact ID format reports Panic alarm to central station. Siren sounds. If Siren (not Bell) in use, the sound is different, not the same sound as Burglary alarm. Panic alarm recorded in history, in LED keypad displayed as H (z). (Z: Zone number, 1-32). For Silent Panic alarm, remove siren and buzzer activation by programming the Panic Zone so. Address: 196-199.

Re-Dial Cycles - The number of times dialer or communicator will dial the programmed telephone numbers. Address: 087. (Recommended value: 3)

Report Opening/Closing (Enable-Disable) - This feature enables or disables the Opening and Closing report for central station. Applicable for residential installation when Opening and Closing reports are not required. Address: 072.

Report Bypassed Zones at Arming (Enable-Disable)- Insurance companies require this feature in certain areas. Address: 072.

Siren Time - Determines the duration of the alarm when zones are activated. Fire and Panic alarm issues a modulated 2-tone siren. 24H and Burglary alarm issues a modulated 3-tone siren. Modulated tones are disabled when Bell Mode is programmed (Address 072). A programmed value of '0' will issue an inaudible alarm. Address: 063.

Swinger Shut-Down Zone - Zones 1 to 32 which have been programmed as Swinger Shut-Down zones will reset twice (3 alarm cycles). This feature prevents repeated false alarms and lowers the security level. Address: 132, 133, 134,135.

SVM (Synthesized Voice Module) Module - Optional module that enables transmission of recorded message upon alarm. Special interface is requires connecting the SVM module. To trigger the SVM unit, program address 072, location 7. SVM pack contains the wiring instructions.

Signal Test to Central Station (Enable-Disable) - This feature enables setting up time of signal test, which is transmitted by the communicator at the required time. The time is set at address 014 in a 24-hour format. Test performed 1 minute after: Powering-up, disarm, programming exit. For example: If the transmitting time is every night at midnight, enter 0000. To enable the signal test, program '4' at address 072.

Address 073 '2' enables the signal test every hour. Other periodical or manual via keypad, CS tests are not possible. (CS is shortening of Central station).

The test signal is on automatically every 24 hours to confirm that system is operative.

The system status (Armed or Disarmed) reported also if extended, or if two-digit format selected. For example: 'A' in address 236 for Armed, and 'D' in address 254 for Disarmed. Signal Test enabled by days of the week programmed at address 077. As 1 is Sunday, 7 is Saturday. An eight (8) enable test for all the week days, 0 clear all. Even if the test programmed at each hour, it will perform only on the programmed days. Address: 072, 073, 077, 236, 237, 254 and 255.

Telephone Line Monitor - Telephone line test will begin 60 minutes after boot-reset (power on) and 1 minute after each arming. If address 083 (dial tone detection) is programmed as 0 (zero), the telephone line test will not be performed. By selecting the test, Abort Delay forced 00 at 069. Address 096 - Time interval between telephone line tests - in minutes. Range 00-99. If '00' is selected no test performed (but failure to get a dial tone when dialing will cause a "Phone line fault" event). To test the telephone line when the panel is Disarmed, program 075 – 6, see also 075-7.





Zone In Use - A zone programmed as an 'In Use Zone' enables activation of the programmed zone. This feature eliminates the need to bypass zones by wire or End of Line Resistor. Address: 100-103.

2.7 □ Step - By - Step Programming

Entering Installer (Engineer) Programming Mode Via AV-701 or AV-702 Keypad

Easy Tip: *You may program any address by entering the address, followed by the value in sequence.*

Power up by connecting AC power with or without battery.



1. Hold down keypad key  (hold-down function).
2. While four LED's are blinking enter programming code ('1 9 9 4')    .
3. If code is valid 'P' will be displayed. The two left LED's (Red & Green) blink to indicate that system is waiting for a new address.
4. Enter the address you want to program (see programming sheet). Current value of address is displayed, and LEDs will blink.

Note: Blinking of 2 left most LEDs, means **system is waiting for new address to be entered; Enter a 3 or 2-digit address (according to address length.)**

Note: 3 blinking LEDs means **system is waiting for new value to be entered; Enter a 2-digit value, or as required.**

EXAMPLE 1:

System in program mode; 'P' is displayed and the two left-most LEDs are blinking.

1. Program zones 1 and 4 as 'Exit/Entry Delayed 1' zone.
2. Address 108 represents the 'Exit/Entry Delayed 1' zones.
3. Press   ; current value of this address is '1' (default program.) Three LEDs will blink and a '1' will be displayed (default program).

- To enter new required value press the address number ; followed by the new required value ('1' and '4') by pressing in uninterrupted sequence; 'U' confirms programming updating.
- 'P' is displayed and the two left-most LEDs are blinking.

EXAMPLE 2:

- Program zone 8 as 24H zone (in default, this is an Instant Zone).
- Address 116 represents the 24H zones.
- Press ; current value of the address is '-' ('-' means blank - no 24H zone is programmed).
Three LEDs blinks and an '-' will be displayed (default program).
- To enter new required value press the address number ; then enter new value '8,' by pressing (zone 8); 'U' confirms programming updating.
- 'P' is displayed and the two left-most LEDs are blinking.

Note: At programming enter '0' in order to delete a feature

EXAMPLE 3:

- Program Siren Time for a 2-minute duration (default 4 minutes).
- Address 063 represents the Siren Time.
- Press ; current value of the address is 04;
3 LEDs will blink and '04' will be displayed (default program).
- Enter address 063, then a new value of '02' by pressing . 'U' confirms programming updating.
- 'P' is displayed and the two left-most LEDs are blinking.

EXAMPLE 4:

Enter an Exit Delay of an approximately two minutes by entering the value '30' in address 062; (30 seconds x 4 = 120 seconds).

EXAMPLE 6:

- Disable Dial Tone Detection. (Used for exchanges where Dial Tone is not the standard 440 HZ tone).
- Address 083 represents Dial Tone Detection.
- Press ; current value of the address is 01;
Three LEDs will blink and '01' displayed (default program).
- Enter address 083 then the new value '00' by pressing . 'U' confirms programming updating.
- 'P' is displayed and the two left-most LEDs are blinking.

EXAMPLE 7:

- 'Enable Siren Test upon Arming' (in default program the siren test is disabled).
- Address 070 represents the 'Enable Siren Test upon Arming'
- Press ; current value of the address is 2 3 4 6 8;

3 LEDs will blink and '2 3 4 6 8' will be displayed (default program).

4. Enter address 071, then enter the new value 1 2 3 4 6 8 by pressing
 . 'U' confirms programming updating.
5. 'P' is displayed and the two left-most LEDs are blinking.

EXAMPLE 8: Report to Central Station

Note: To enter data use two digits entry, i.e. in address 201 to change the transmitted code from the default value '3' to '5', at keypad enter '0' and '5' (not 5).

If '5' entered, an 'E' (Error) appears

① Enable communicator to report to central station (in default programming communicator is disabled, and dialer is activated upon alarm). Telephones 2 and 3 (refer to program sheet) are used to communicate to central station.

② Contact the central station to get receiver format, event codes, subscriber number, handshake frequency (1400 or 2300 Hz), and telephone number(s). Two telephone numbers are available, 'Tel. 2' is main central station Tel. Number and 'Tel. 3' is backup, in case 'T. 2' fails.

Do not program different formats for each telephone.

Refer to part '7' of the programming sheet. Fill in central station's details. For example, if the receiver format is Radionics Fast for Tel. No. 2, enter '02' in address 201.

Most important parameters are the Receiver Format, Handshake frequency and Data Format.

Data Format: This parameter describes how data transmitted to central station. Data Format types are divided into 3 main groups: Extended Format, 2-digit Format (first format = type of event, second digit = event zone) and Single Format. In all formats, Sum-Check (parity) is optional, depending on the specifications of central station receiver.

Extended Format Reporting: Extended Format and 2-Digit Format allows communicator to transmit an extra digit, which provides additional information as zone number and event occurred. Program 01 (Extended) in address 207. Contact your central station for required Data Format, protocol type and parity.

Data format '3 x 1' means three digits for the subscriber number and 1 digit for the event.

For example:

System installed with the following transmission specifications for Tel. 2:

Subscriber number is 456 (program at address 260-262)

Report on 'Low Battery' selected (program at address 108 and 128)

If 'Low Battery' occurs, communicator will transmit:

456F - Subscriber '456'

FFF8 - Low Battery ('F' = FAULT)

Single-Digit Format Reporting: If receiver accepts only single digit format, program 00 or 01 in address 205, and 00 in address 207.

The data format 4 X 1 or 3 X 1 means four or three digits for subscriber number and 1 digit for event.

For example:

System installed with the same transmission information for Tel. 1, but single-digit format:

456 - Subscriber '456'

F = Low Battery, will report '456F'

Two-Digits Event Format Reporting: Reports 2-digit code for each event. Enter 02 or 03 in address 205, and 00 in address 207.

④ Refer to address 105 and fill out the zones to be reported, and in address 106 the events to be reported. Default programming is useful in most cases.

⑤ Enter the alarm and restore codes in addresses 110 to 163, according to single or extended data format transmitting.

⑥ Enter the closing and opening codes in addresses 220 to 227, according to number of users.

Forced Opening signal transmitted when Opening (disarming) the system using an inverse code.

⑦ Enter the subscriber ID (subscriber number) in addresses 260 to 283, using 3 or 4 digits according to programmed format entered in address 205 and/or 206.

Opening and Closing Reporting to Central Station

By default, (address 072) Closing/Opening reported to central station. The report contains the subscriber ID; the Closing/Opening events, and the user number (1 to 8).

In order to avoid reporting Closing or Opening for specific user erase the user Closing or Opening code. The system will check for non-reporting programming and will not initiate dialing if the user is programmed for non-reporting of Opening or Closing.

For example: User 2 is not to be reported for Closing: Program 00 in address 222; or, user 3 is not to be reporting for Opening; program 00 at address 242.

If you check the contents of address 242 (00 is programmed), a '-' will be displayed, indicating that this location is blank (empty).

To enter Subscriber ID codes faster and easier as a sequence of four digits programming, refer to addresses 360 to 376. For special applications, you may also enter the ID's address by address (refer address 260 to 283).

Communicator's Subscriber ID Codes - EASY Programming

Refer to part 10 of the programming table (page 32); System is in program mode, enter ID address, 4 LEDs are blinking, enter the subscriber ID code in sequence.

Example: Your subscriber ID number is 2170 for Closing/Opening of telephone 1; refer to address number 376. Keypad in programming mode, 'P' is displayed, press 376, four LEDs are blinking, enter 2170.

Note: EASY Programming is not included in the *EasyLoad* screen (programming via computer).

Note: Even if your communicator receiver requires three digits for the subscriber ID, enter four digits. The system will ignore the fourth digit.

If your central station requires programming of letters as well as numbers, refer to the HEX programming description. Use the regular programming method of entering each letter or number in each address, as explained in the programming table (HEX method).

Contact ID Format (known also as Ademco Express): This is the fastest to program and easiest to use format, with communication speed achieved by the DTMF signaling.

When using this format, program only the CS telephone numbers and subscriber ID; all reports automatically transmitted, without programming anything else.

2.8 Reset System to Default Programming

In case you made programming changes and the system operation is wrong it is recommended to set system to the defaults program. **Warning**, this function erases all codes and system programming settings.

1. Enter program mode.
2. Go to address 200 and enter '6' and '9'. Display will show **E P R**, and system will revert to factory default program. Code No. 1 is 1 2 3 4; programming code will be 1 9 9 4.

Quitting and Updating new Programming via AV-701 Keypad

Upon programming completion, hold down key 9.

Wait for a long beep, and then release the key.

When 'P' is no longer displayed, the system has reverted to Disarmed mode.

Note: Erroneous or conflicting programming features are discarded by the system upon quitting program mode. For example: Programming the same zone as 24H type and Delayed zone will be recognized only as a 24H zone.

Reset System to Default Codes (In case code is lost)

To enable this feature, enter 8 in address 072.

Hold-down keys Press both together during 5 seconds after power-on (by applying AC and Battery); after 2nd beep, release keys; 'U' will be displayed 3 times in confirmation.

User code No. 1 (1234) and programming code (1994) will reset to default.

2.9 Dialer- Communicator; explanation and Programming

Series 2000 Defining the Communicator and Dialer feature

Communicator

The Communicator is in essence, a dialer that enables communications with a central station digital receiver. The Communicator reports (upon programming) panel events such as Opening, Closing, Alarm, and Low Battery.

The Communicator's programmable features enable compatibility with different central station receivers. The receiver's most important features are the Format (Radionics, SESCOA, etc.) and Data Transfer Mode (1 x 3, 2 x 4).

The four programmable telephones in the 2000 Series (telephones 1 to 4) act as dialers, while Tel. 2 and 3 (Tel. 3 is backup for Tel. 2) are optional as communicator or dialer.

Program the communicator and dialer options at addresses 201 and 202. Do not program only Telephone 3 as communicator. At alarm, Tel. 2 and 3 are in priority, if programmed as communicator. The communicator phones are first to communicate (before dialer phones).

In the 'Communicator' mode, the panel will dial several times until the central station sends a confirmation signal (Kiss-Off) that all events received. The Kiss-Off signal turns the communicator off until the next event occurs. If the CS telephone number is busy, panel will re-dial automatically. The number of dialing attempts (cycles) is programmable at address 087.

In case first central station telephone number (Tel. 2) does not get Kiss-Off after several attempts, the system will dial the back-up number - Tel. 3. Program both Tel. 2 and Tel. 3 as communicator. Program the same reporting format for Tel. 2 and Tel. 3. When the system is disarmed, AC Fail is reported 30 minutes after power fail to prevent false alarms.

To cancel the communicator dialing: Enter to Program Mode and Exit program.

Dialer

The Dialer acts similarly to the communicator, except that the panel sends a pre-defined alarm siren tone or vocal message with SVM-40/60, (not a digital signal) to a regular or mobile telephone. Unlike the communicator, the dialer does NOT identify busy signals; program the dialer to re-dial several times (default is 3 cycles). This feature is programmable at address 087. A 'Follow-Me' feature (see explanation in Glossary section) is applicable only with the dialer, in alarm the Follow-Me number dialed first if communicator not selected.

To cancel the dialer dialing: Arm and then Disarm the system.

Note: Upon alarm, the communicator has dialing priority over the dialer.

Programming Telephone Numbers

1. Enter Program mode as described in programming description.
2. Select Dialer or Communicator mode (addresses 201, 202). For dialer selection, enter 00 in address 201 for Tel. 2, and in address 202 for Tel. 3. (Tel. 1 to 4 is in Dialer mode by default). If communicator is selected, use both Tel. 2 & 3 (not Tel. 03 only). Tel. 3 is backup for Tel. 2.
3. Enter the required telephone numbers (maximum 16 digits) at address 010 to 013. For example program Tel. 1 to be 00972-36816767; Press 010, the two left LED's blink, enter the number 00972 in sequence, hold-down '0' (pause), enter 36816767; wait for 'u' confirmation. To insert * in the telephone number; Hold-down keys # and * (panic); * will be displayed as 'A.' (* is valid during dialing in DTMF mode).
For Dialing Pause hold-down key '0.' Note: Two pauses (one following the other, or a pause at the end of the telephone number) are not valid. Maximum 4 pauses per Tel. number.
4. To quit the programming mode Hold-Down key '9'.

2.9.1 □ Deleting Telephone Numbers

1. Enter program mode, confirmed by 'P' in display.
2. Press 010 (address 010) for telephone No. 1. At 3 LEDs blinking, hold-down key '9.'
3. Follow same procedure for the telephone requiring deletion.

2.9.2 □ User Programming of 'Follow-Me' Telephone Number

To program the Follow-Me number, disarm the system ('USE' mode).

1. Hold down key [6] twice, wait for the blinking of 3 LEDs.
2. Enter Telephone Number (maximum 16 digits and 4 pauses), and wait until all LEDs stop blinking. The 'Follow-Me' number programmed.
3. To delete 'Follow-Me' number, access 'Follow-Me' programming mode as described in paragraph 1, but do not enter any digits.

To program the system to automatically erase 'Follow-Me' number after Disarm, see Address 071 on Programming Sheet.

2.10 □ Quitting Programming Mode

Upon completion of programming, Hold-Down key 9.

2.11 □ Verification of Current Programming

(Programmed Values)

Enter to Program Mode by holding down key  and enter programming code. 'P' is displayed. Enter address to be verified. The value of that address will be briefly displayed and three LEDs will blink.

Wait until LEDs stop blinking before verifying next address.

Upon completion, you may disconnect all power.

All programming will remain intact during System power-up.

2.12 □ Downloading from a computer

Up and downloading via Modem and Computer (EasyLoad DOS version 3.50 or Windows)

EasyLoad Introduction

The remote up and download feature enables fast and simple programming of *EasyLoad* panels. Programming tables, codes and other features may be up & downloaded from an onsite PC (DOS Mode, 386 or higher) by using an AV-232 adapter cable, or via telephone using modem and 'EasyLoad' software. 'EasyLoad' is compatible with DOS, Windows 95/98 and Windows XP.

To program EasyLoader control panel by remote PC, a compatible modem required. The modem specifications is critical, before attempting to operate the EasyLoader make sure your modem meet the following: Supports the Hayes AT command, Bell 103 compatible, DOS mode is selectable.

EasyLoad software supports most modems manufactured after 1994, including: US Robotics, Hayes, Viva, Boca, Microcom, Netcom Roadster 288, Acer 336, PCMIA 3 com 3CCM156B,

Motorola Lifestyle 28.8, Dataplex Multispeed V.32bis, Netcom Smart modem 56, Acer AME-MU00, ABC 56K V.90, and other Hayes and Bell 103 compatible modems.

Installing *EasyLoad* on your Computer

Insert the *EasyLoad* diskette in the floppy drive A (or B) and type 'A:' (or 'B:'). At prompter 'A:>' type 'AVGAD217' (AVGAD217 is the file name). The installation program will guide you, and will install *EasyLoad* automatically by creating a new directory on your hard drive, called AVGAD, or a name of your choice.

To start your EasyLoad: at the prompt 'C:\AVGAD>' type 'ESAV'.

Important! The most current updates and *EasyLoad* features are in the READ ME file. Read it carefully before using the EasyLoad. Factory default access code is AVGAD123. Change it when installed. Update it periodically.

The first time you run the program, missing "Files Message" displayed (the database), answer 'Yes' to create them.

The main *EasyLoad* menu contains seven selectable fields. Enter those fields by using the navigation arrows on your keyboard, or by typing the field number.

Using a mouse is highly recommended. The keyboard can also be used to navigate through the fields, e.g. Move from field to field using arrows (when possible), the TAB key (forward), SHIFT + TAB (backward), ALT key + Highlighted letter. Confirm input in text fields by hitting the ENTER (return) key. In the main menus, you may type the highlighted digits for fast access.

Step 1: Configuring your Modem

Configure your communication port using the SET-UP entry from the main menu (entry 7).

For DOS modems the required COM/IRQ combinations are:

COM1, COM3 - IRQ 4

COM2, COM4 - IRQ 3

To initialize the modem properly, use the Auto Detect option before trying to CONNECT, ignore errors that are reported during initialization.

The integrated modem in latest (version 2 and later) EasyLoader control panels operates in Answer mode.

The dial suffix from the Set-Up screen is no longer relevant! The modem will be silent until the control panel answers the call, then the Modem noise is on (the carrier detection procedure).

After connection made, the modem's speaker will turn OFF. In this operation mode, you will be able to hear the call progress tones (dialing, ringing or busy). If the phone line is busy, the program will notify you and will disconnect the telephone line.

To get an outgoing telephone line from an extension, fill in the PABX entry on the set-up screen. Type the digit needed for the outgoing line (usually 0 or 9) followed by a W. The 'W' will pause the modem until it gets the second dial tone (from the outgoing line) thus avoiding blind dialing.

Troubleshooting: Where telephone system installed, local PABX stations (telephone system) are fitted with internal modems for remote set-up. These stations, much like the control panels, activate their modems in ORIGINATE mode.

When connecting through such a station to a telephone number that without getting an answer, the station will eventually activate its modem in response to the computer's modem. The communication program then informs you that connection to the panel established! A few moments later, it will disconnect, because there is 'no response from panel!' If you usually dial to control panels that will answer after a long while and the phone station interferes each time, try to use a direct line.

Step 2: Opening a Client Account

When opening a client account (selection 1 in the main menu), make sure to enter the 'Panel Phone Number.' This is the telephone number to which the EasyLoad program will dial for the up and download operation. Fill in all client details.

The first time you open (create) a client account, you must choose the control panel model. You cannot modify it later!

To open another client account, select New and enter the account number.

To display the list of all the client accounts, press on the 'List' button. You will get a sorted list of the clients. Press the SPACE bar to have the list sorted by NAME or Account Number.

To search for a name or any string, press the 'Search' button.

Starting version 2.03, AV-2016 modems operate in Answer mode.

This code is initially empty (a string of spaces). When leaving the factory, the control panel is initialized to an empty code too.

The first time the PC contacts a 'virgin' control panel it transfers the dealer code (from the client record) to the panel's memory.

From this moment, any further dialog with that panel will require the dealer code. Note that the dealer code in the client record is empty, it 'matches' the panel empty code and communication is possible.

This means you can choose not to use dealer codes. On the other hand, once a dealer code transferred to the panel, to erase or modify the code is impossible. Access to the panel is granted only with this code.

To open another client account, select New and enter the account number.

Step 3: Modifying the Programming Table

Select field 2 from the main menu. This will take you to the Programming menu. All settings are the factory defaults.

Select the programming table section you would like to modify. Save and exit.

Feature and code modifications are updated on the control panel at upload.

You can modify or inspect the programming table while connected to the control panel ('on-line').

Warning: The control panel will answer an incoming call upon the number of rings set in the Dialing Parameters, in address 091. The control panel will not answer the telephone when this number is set above 20 rings. The factory default is 10.

Step 4: Connecting

Check your PC time and date before connecting to a control panel!

Upon selecting 'Connect,' the modem will dial to the currently selected client (see Step 2, for programming client telephone number).

While the connection established, a high-pitched tone is heard through the modem's speaker (this is the carrier sound). Learn to recognize the tones, and pay attention to the sound, because in its special operating mode, the modem cannot detect BUSY and other call progress signals.

The PC modem will hang up automatically if it does not get an answer from the remote panel in 60 seconds.

When the remote Control Panel answers a call and detects the carrier from the PC modem, the panel enters the programming mode and will remain in this mode until it gets a disconnect command from the PC, or connection is lost due to bad phone line (loss of carrier). After disconnecting, the Control Panel remains in its previous operating mode unless its status was modified in the 'Commands to Panel' section.

If a user attends the remote panel, cancel connection by holding down the '9' key on the keypad.

While connected, the programming table can be downloaded, modified and uploaded to the control panel.

If the history log is downloaded, it can be viewed also after disconnecting. At present to print history is not available.

Important: The Control Panel status (Armed/Disarmed), as set by the communication program, is changed AFTER disconnecting from the remote PC.

Upon reception of the 'change mode' command, the control panel replies with the 'new' mode. It might be different from the one displayed on the computer monitor.

For example: Group Bypass will not be acknowledged if no such zones were programmed. The same applies to manual bypassed zones. If one accidentally tries to bypass all the zones, the control panel will discard all bypassing.

Address 092 enables 'Answer Now' (answers remote computer after 1 ring). The user attending the control panel can reduce the number of rings before answer to one ring.

Answering machine bypass

In case the alarm panel connected with fax or answering machine on the same telephone line (not recommended) enable the Answering Machine Bypass or Answer Now features (otherwise connection is impossible).

To enable the feature:

1. Program 7 at address 076
2. Program at least 20 seconds at address 097 (Ring Time Out)

Now dial to the control panel, count at least three rings and disconnect, dial again immediately – the panel will answer at first ring.

When Answering Machine Bypass enabled, the control panel will answer at first ring if:

- There was a pause of at least 10 seconds from last ring
- The panel already counted at least three rings before the pause
- Number of rings to answer (at address 091) is less than 20

Notice:

The panel will answer (in a normal mode) if there is no pause and the rings counted exceed (or equal) the number programmed at 091.

Step 5: Disconnecting

When download completed, disconnect the PC from the remote Control Panel by selecting 'Disconnect' from the main menu.

Control panel status after disconnection:

A remote PC might connect the control panel while unattended by the owner, the following must be taken in account:

⇒ The panel will always ARM (if told so by the remote) regardless of the status of zones. That means that currently open zones will not prevent the panel from Arming (not possible with the keypad).

⇒ After a remote connection the history log is not cleared.

⇒ For Belgian standard user: If the alarm was caused by 'Tampering' the zones, and the 'Lock System after Tamper Alarm' feature was programmed, the system will remain locked while it is Armed.

⇒ If the control panel was contacted after an alarm, and then Armed or Disarmed, the last events are not cleared. Thus, even after system disarmed by the remote PC, the keypad still displays the zones that caused previous alarms and the status LED blinks (although there are currently no open zones). Pressing the Reset (hold down '9') key will clear these alarms.

⇒ Instruct the owner to clear the history log from time to time. This will keep the history log reasonably short (the maximum event number is 250) and will cut down the download time.

Zone Description Transfer

Starting EasyLoad version 3.00 Zones and Logo texts are possible to Upload/Download via PC. Texts uploaded automatically to the keypads after communication is closed.

Events logging

'History' events are 'date' stamped. The control panel time and date are synchronized to the remote computer when connection is made (as well as when the control panel status is changed by remote PC command).

The control panel date can also be locally set, using the keypad by the hold-down '0'+ '2'+ddmmy ('0' and '2' mean 'hold down' keys 0 and 2).

Instruct the control panel user to update the system time and date after a total power loss ('h' is repeatedly displayed at the keypad).

The EasyLoad software designed to support international users, to modify and translate the LANGUAGE.TXT, LANGPROG.TXT, LNGPRG16.TXT, and HELPPROG.TXT files use an ASCII editor. You can translate captions in these files to other languages.

In the DEF2016.TPL, DEF2016.TPL and DEF2016A.TPL files, some captions can be translated (be careful with these files!). **Caution!** Make sure to backup the files before altering them. See details in the files themselves.

Local Up and Download via PC

When using the AV-232 interface (special RS-232 cable and interface connecting the PC to the 2016 control panels) you must set panel to programming mode.

In programming mode ('P' is displayed), type 77 at address 200 (i.e. type 20077) before attempting to establish connection. When using the AV-232 interface, the transfer rate is eight times faster than through the modem. With local PC, use the same procedures as describe below.

Copying the Programming Table

To cut down the time spent on programming several accounts with practically the same data (communicator parameters, communicator codes, central station telephone numbers, etc.) you may create a few 'master' accounts. For each control panel model you intend to use, create a 'master' account containing the relevant programmable data. This 'master' account is in no way different from a regular account. Choose an account number that is easy to remember and enter a short description instead of the 'client name.'

After creating a new client account, exit to the main menu and choose 'Copy Programming Table' (entry 6) option. In this screen, type the number of the 'master' account you want to copy. Confirmation of the copy operation will transfer the whole programming table of the master account to the currently open client file. You can now make other adjustments by choosing the 'Modify Programming Table' (entry 2).

Full instructions and latest features enclosed in the EasyLoad software diskette.

3. PARTITIONED SYSTEM – TYPE AV-2016DP, 8 PARTITIONS

Note: The AV-2016DP panels require entering your user code before the necessary activity (hold down function, code entry, etc), this is different then none-partition panel type AV-2016D.

3.1 Partition Definition

Partition means a group of zones that acts as an independent subsystem. The subsystem can be armed and disarmed separately. Add the AV-816 zone expander for 32 zones system.

Partition '1' is a 'common partition' that automatically Arms when **all** other partitions are Armed. Apply partition 1 for example; in installation with common corridor for few offices, in the corridor few users need to enter. In fact it is armed a moment after the last disarmed partition is Armed.

It is automatically Disarmed a moment after any one of the partitions is Disarmed.

Partition 1 is a fully featured partition, programmed with the same features and zone types as of other partitions. Partition 1 can also have individual users assigned to it however, remember that even if this partition is Armed by its individual user(s) it will Disarm as soon as **any** other partition is Disarmed. Likewise, it will automatically ARM as soon as the last Disarmed partition is Armed.

Zones in the group can be bypassed, Auto Bypassed and Group Bypassed. Any zone bypasses on Partition 1 (common partition) are only released upon disarm by a user assigned to partition 1 or by disarming globally (using user 1 code).

Each partition can include Delayed and Following zones. They will affect only their partition. Entry and Exit delay are independent from other partitions operating modes and condition.

The siren and the keypad warning will be active while alarm is still present in some partition. Outputs activates as requested by partitions. This means that although a user disarms a partition in trouble, the siren and the outputs might be still be active if other partition is in alarm. An exception to this rule is the dialer.

Each user might operate one partition only. The installer programs the partition to which the user is given access.

Code 01 (User 01) is a 'Master Code'. Code 01 Arms or Disarms the whole system. Code 01 can perform operations not allowed to other users.

By default, there is one partition in the system. This partition includes all the zones.

If there are at least two partitions:

- ➔ A zone cannot be part of more than one partition.
- ➔ Not allocated zone, or if zone allocated to more than one partition is defaulted to partition 01.
- ➔ System discards zones without a partition.
- ➔ Partition 1 automatically Arms when all the other partitions are ARMED.
- ➔ Partition 1 automatically disarms a moment after one of the partitions is DISARMED.

In a partitioned system users code linked to a partitions.

By default, all users linked to partition No. 01.

User 01 is always linked to partition 01, although he Arms or Disarms all the partitions at once!
A user code linked to a non-existing partition is ignored.
As an exception, User 7 can activate the 'door' relay if feature was programming, if such, code 7 cannot do make other function.

3.2 □ AV-2016DP - Users Options

User (02 to 16) can:

Arm and disarm his partition
Bypass (shunt) zones in his partition only
Group bypass

User (02 to 16) may display:

Status of the partition, the zone status in his partition
Bypassed zones
Short history of his partition
Tampered zones history

User 01 (Master) options:

Arm and disarm all the partitions at once. User 1 cannot Arm or Disarm a specific partition.
User 01 can bypass zones from all the partitions that are currently disarmed, before a global arming, he can enter 'Group Bypass'.

User 01 may display:

Status of all partitions
Status of all zones in all partitions
Bypassed zones in partition currently disarmed, short history of all partitions, detailed (long) history display, clear history, set system time, display lasts users.
Can perform Siren test, dialer test, fault find test, follow me phone number programming, user codes programming.
Some of the commands are allowed when all partitions are Disarmed, others only when at least partition 01 is Disarmed.

3.3 □ AV-2016DP - Keypad Operation

Enter a USER code first to precede any function, then press or hold-down the required key.

- ➔ Pressing and holding long enough any keys cancels previous input.
- ➔ Three (3) user code errors lock the keypad.
- ➔ Pressing * and # for Panic does not require a code (Require programming location 070-8).
(A panic alarm is sent as belonging to partition 1 (Common Partition)).

When a valid code acknowledged the four LEDs on the keypad start blinking: The system is waiting for a command.

Arming and Disarming

('XXXX' means USER CODE)

Arming: XXXX then key 1 - Arms partition (of specific user)

Arms all if USER 1 code entered.

Arming with open zones in partition will be denied, troubled zones displayed.

Arming with Group Bypass: XXXX then key 3 - Arms partition (of specific user) and the defined Group Bypass activated.

Arming with Group Bypass 2: XXXX then key 0, than hold down key 2 - Arms partition and the Group Bypass 2 activated.

Disarming: XXXX then key 2 - Disarm partition

Disarms all if USER 1 code entered.

Note: A partition (or all the system) can be RE-ARMED without previously disarming (for example to stop an ALARM).

If a user repeatedly ARMS a partition (for fun), the event is reported to the central station only if there was a reason for the command.

If the system was ARMED and an alarm occurred, a re-arming reports the event. Otherwise, nothing is reported or recorded in history (same applies to continuously disarming).

Arming via Key switch and key 5

The control panel may be Armed or Disarmed also by KEY (if feature is enabled). The key change affects all the partitions. It is similar to an Arming or Disarming by USER 01.

When using the momentary key-switch option, the new operation mode will be the opposite of the current one in partition 1.

Any user can Arm the system (all the partitions) by using the '5' key (if programmed so).

Displaying Partition Status

Entering XXXX - Partition status is displayed. If Code No. 01 entered, all the partitions are shown.

Partition status is displayed as follows:

P1_dr P2_dL P3_Ar P4_AL

P - partition

dr - disarmed (OFF) no alarm

dL - disarmed with some alarm

Ar - Armed (ON) no alarm

AL - Armed with some alarm

Keypad functions

User code typed in reverse order: Disarms partition and sends an Ambush code to the central station. Available when the communicator is enabled (Locations 021, 022).

XXXX- User 7 only: Activates the SLO-1 (for door relay) must be programmed.

XXXX 0 + ZZ - Bypass zones in partitioned system; enter user code, then '0', Shunt Led blinks fast, now enter the zones to be bypass (01, 02, 03,.....). User 01 can bypass zones in any disarmed partition.

XXXX 0 + 00 - Group bypass in partitioned system, is the same procedure as zone bypass. If issued by User 1 it sets the group bypass for all partitions. Group bypass in effect only after the partition is armed (and if it was armed no more then 60 seconds after the command was entered).

Note: A user cannot bypass all the zones in his partition, the system reject such attempt . Program the Auto-bypassed zones according to your application. Together with the manual and group bypass zones, they can amount to the total zones in the partition.

In such case, the system will reject all zones that are not manually bypassed.

3.4 AV-2016DP - 'Hold Down' Keypad Functions

MMMM represents the Master code (User 01). 'XXXX' means other user code. DDDD means Dealer code

* & # - Pressed together, the * and # will start a 'PANIC' alarm (H displayed). This sets the alarm in partition 01. To disable Panic alarm, enter Code No. 01, or any user that has access to partition No. 01.

**Example, entering to Programming Mode: DDDD + '8'.
Enter programming code 1 9 9 4, 4 LEDs blinks, hold-down 8, 'P' is displayed. System is now in programming mode. To exit, hold-down key 9.**

XXXX '0' - Displays short history in user partition

MMMM '0' - Displays short history in all partitions

MMMM '0' + '0' - Displays detailed history

MMMM '0' + '1' - Displays system time

MMMM '0' + '1' + HHMM - Sets system time

MMMM '0' + '2' - Display system date

MMMM '0' + '2' + DDMMYY - Sets system date (DAY-MONTH-YEAR)

XXXX '0' + '3' - Tampered zones history in particular partition

MMMM '0' + '3' - Tampered zones history in all partitions

MMMM '0' + '4' - Clear all history

MMMM '0' + '5' - Display last two users Arming and Disarming

MMMM '1' - Siren test

XXXX '2' - Displays shunted (bypassed) zones in partition
MMMM '2' - Displays shunted (bypassed) zones in all partitions
XXXX '3' - Display status of zones in partition
MMMM '3' - Display status of zones in all partitions

XXXX '5' - Toggled chime mode (only if all partitions are OFF)
MMMM '6' - Display 'Follow Me' phone number
MMMM '6'+ '6' - Erase 'Follow Me' phone number
MMMM '6'+ '6'+ PPPP - Program 'Follow-Me' number (PPPP = follow me number)
MMMM '6'+ '6'+ '7' - Dialer test

MMMM '7' - Enter Fault Find mode (command is acknowledged only during the first 15 seconds after the system was disarmed)

MMMM '8' - Enter user codes for program mode. Default programming code is 1234.
DDDD '8' - Enter Dealer code (Installer) programming mode. Default code is 1994.
MMMM '9' - Stops dialer test, clears the phone fault ('C') indication.
XXXX '9' - Stops buzzer and resets 'day' troubles in partition. Activates the output used for fire detectors reset.

Programming notes

Addresses 533 through 547: User's partition.

These addresses contain the partition associated to a user.

Enter a two-digit number in the range 01 - 08 in these locations.

Note: No matter what value is entered for user 01, it will always be considered as set to 1.

Programming partitions: Addresses 500 through 531.

By default, 16 zones allocated to partition 01.

A zone cannot be part of two or more partitions. Therefore, even if zones are programmed in several partitions, after exiting programming mode the system 're-orders' zones and keep them in the lowest numbered partition. For example, if a zone programmed in partition 2 and 4, it is erased from partition 4.

From this reason it is recommended to erase zones from lower partitions if they are to be programmed in higher partitions. As a start, clean all locations for partition 1, then program zones in other partitions.

All the 'orphan' zones (those that had not been programmed somewhere) automatically added to partition 1 (the system does its 'book keeping' after programming mode is exited).

Central station reporting

For Central Station reporting with the partition number, program the reporting format as Contact ID. In Contact ID the partition number 1 to 8 is reported after the user account number. If your central station receiver is interfaced with a dedicated software the partition number should be recognized automatically, in case that it's not contact your software provider to define this feature.

3.5 AV-2016DP LED Indicators

AV-701 Keypad: Four LEDs provide visual indication of System status, as well as confirmation of various modes.

Keypad LEDs indication

Armed Led-Red	AV-2016	AV-2016DP
Off	System Disarmed	All partitions Disarmed
Blink slowly	An alarm is triggered	At least one partition is armed
ON steady	System Armed	All partitions are ARMED
Blink fast	Mode does not exist	Alarm triggered in a partition/s

Status LED-Green	AV-2016	AV-2016DP
Off	System Disarmed	Some partitions are Armed
Blink slowly	Some zones are open	Some zones are open
ON steady	All zones OK	All zones OK
Blink fast	Some zones have been tampered	Some zones have been tampered

Shunt LED-Orange	AV-2016	AV-2016DP
ON steady	Some zones are bypassed	Some zones are bypassed
Blink slow	Group bypass entered	Group bypass in some partition
Blink slow	8 seconds after Armed with Group Bypass	8 seconds after Armed with Group Bypass

Fire LED-Red	AV-2016	AV-2016DP
Blink slow	Warning before Fire alarm	Warning before Fire alarm
Blink fast	During and after Fire alarm	During and after Fire alarm

Note: At alarm time Troubled Zones displayed at the Keypad.

3.6 System Codes

The control panel stores up to sixteen different Arm/Disarm codes and one installer (dealer) code; each code may contain 1 to 6 digits. 1 2 3 4 is by default code No. 01 (master code).

The user(s) code must not start with the same numbers as the installer programming code (1994).

Do not use same codes or same first digit for few codes, for example if code No. 1 is 1,2,3,4 prevents programming code No. 2 to be 1,2,3,4,5,6.

The control panel may be Armed or Disarmed also by KEY (if feature is enabled) or wireless remote control.

Manual Answer Now (modem setting of the AV-2016DP) Partition System

See address 092, set to '00' to disable or '01' to enable (01 by default).

Procedure

1. Address 092 set to 01.
2. Enter User 01 code (1234 by default), hold-down key 8.
3. 'u' is displayed.
4. Enter 66, 'A' displayed and few beeps in confirmation, no other indication. For next 5 minutes, after the first ring, the modem is connected.

4. TROUBLESHOOTING

Symptom	Possible Cause	Remedy
Keypad failure	<ul style="list-style-type: none"> • Incorrect wiring • Blown fuse 	<ul style="list-style-type: none"> • Check color wire connection • Check power at panel
Keypad displays '8,' but does not react to pressing of keys	Incorrect connection of data wires	Check Orange and Yellow wire (or terminal block) connections at keypad and system
Keypad displays '8,' and keypad buzzer is sounding	Zone 8 is troubled	Close or bypass zone 8 (zone 8 is 24H-type by default)
3 LEDs flashing, ≡ is displayed	Power failure	<ul style="list-style-type: none"> • Connect AC power, verify that main socket is alive • Check transformer
'H' is displayed	Panic keys were pressed	Arm and disarm
'≡' sign is displayed (blinking)	Power failure occurred	Arm and disarm
No siren upon keypad panic, but siren test is OK	Faulty programming	Panic alarm address should have a value greater than '0' (zero). See address 050.
No siren upon alarm at troubled zone	<ul style="list-style-type: none"> • Programming • Siren fuse • Alarm device blown 	<ul style="list-style-type: none"> • Siren time-out addresses should have a value greater than '0' (zero) • Check fuses and • Check that sirens operates
Dialer dials, but no alarm message is transmitted on telephone	<ul style="list-style-type: none"> • Faulty programming • Hardware fail 	<ul style="list-style-type: none"> • Check address 201 and 202 • Test telephone line
Zone is troubled even though EOL resistor is connected or zone is wire bypassed	<ul style="list-style-type: none"> • 'EOL Zone' feature incorrectly programmed • Incorrect resistor value 	<ul style="list-style-type: none"> • If EOL mode is programmed, connect resistor across zone terminal for testing • Use 2.2K resistor

System self-arming	<ul style="list-style-type: none"> • Remote key wires are too long • Key '5' was programmed for 'Instant Arming' 	<ul style="list-style-type: none"> • Run shorter wires from panel to remote key • Disable key '5' (instant arming) by reprogramming address 071
Display of '≡' and Arming is denied	Instant zone is troubled	Bypass or clear the troubled zone
Cannot disarm system	<ul style="list-style-type: none"> • Code was changed before instant arming • 'Lock in tamper mode' 	<ul style="list-style-type: none"> • Keypad wires are too long • Disable instant arming • Verify address 071 value '6'
'P' displayed after attempt to change end-user code	Verify the last User-Code	You may proceed with 'Default Programming' to revert system to default codes
'8' displayed keypad keys do not response	Power to keypad is OK, communication wires are incorrectly connected, or are disconnected	<ul style="list-style-type: none"> • Make sure wiring is correct • Check wires at panel • Replace keypad
'L' displayed upon arming, but battery is OK	Battery fuse fail	<ul style="list-style-type: none"> • Test system without AC power; if inoperative, battery fuse has activated • Check battery wires & fuse, if fuse is hot, power down and wait
In alarm mode, Aux. power drops below 10V	Aux. power overloaded	If current consumption of Aux. power exceeds max. rate, add external power supply (AV-21)
No Entry delay	Key '4' (delete delays) was held down	Arm and then disarm to cancel this function
Programming fails to update features	Faulty programming	Verify programming features
Upon Arming, Bypass (shunt) Orange and Red LEDs light up	Auto bypass of instant zone was programmed	Verify programming address 034 - Zone Auto Bypass
Dialer does not dial on alarm, even though line and connection are OK	Programming error	<ul style="list-style-type: none"> • Dialer or communicator time-out addresses should have a value greater than '0' (zero)
Remote signaling outputs do not drive (-)	<ul style="list-style-type: none"> • Overload • Incorrect testing 	<ul style="list-style-type: none"> • Current consumption from output to load should be not higher than 50 mA (test outputs by connecting voltmeter from output to (+) Aux. power; upon signaling, meter should read 12.5 to 13.6 Volts)

Symptom	Possible Cause	Remedy
Buzzer sounds in disarm mode	Hold-down function was entered or Day zone triggered	Arm and then disarm to cancel chime and fault find features, or hold-down key '9' to reset day zone alarm
User code is unknown	User forgot the Arming code	1) Enter to installer programming mode, to address 099. Set new user code. Set system to default codes (If programmed so). 2) Refer to 'Resetting Codes to Default feature, page 30
Panel's PCB is getting hot, system doesn't function normally	<ul style="list-style-type: none"> • AC power is too high • Power supply overloaded or faulty battery (shorten) 	<ul style="list-style-type: none"> • Measure the low AC power; should not exceed 17V • Try to disconnect sensors, keypads or other loads that consume high current

For additional assistance, please contact first your local distributor, in case of none solved problem contact Av-Gad Systems Ltd, mention your vendor.
Our telephone: +972-3-681 67 67, **Fax:** +972-3-683 5505, **E-mail:** avgad@inter.net.il
Mail: POB 49 080, Tel-Aviv 61 490, Israel. **Web site:** www.av-gad.com

SECTION V: WIRING DIAGRAM AV-2055D, AV-2088D

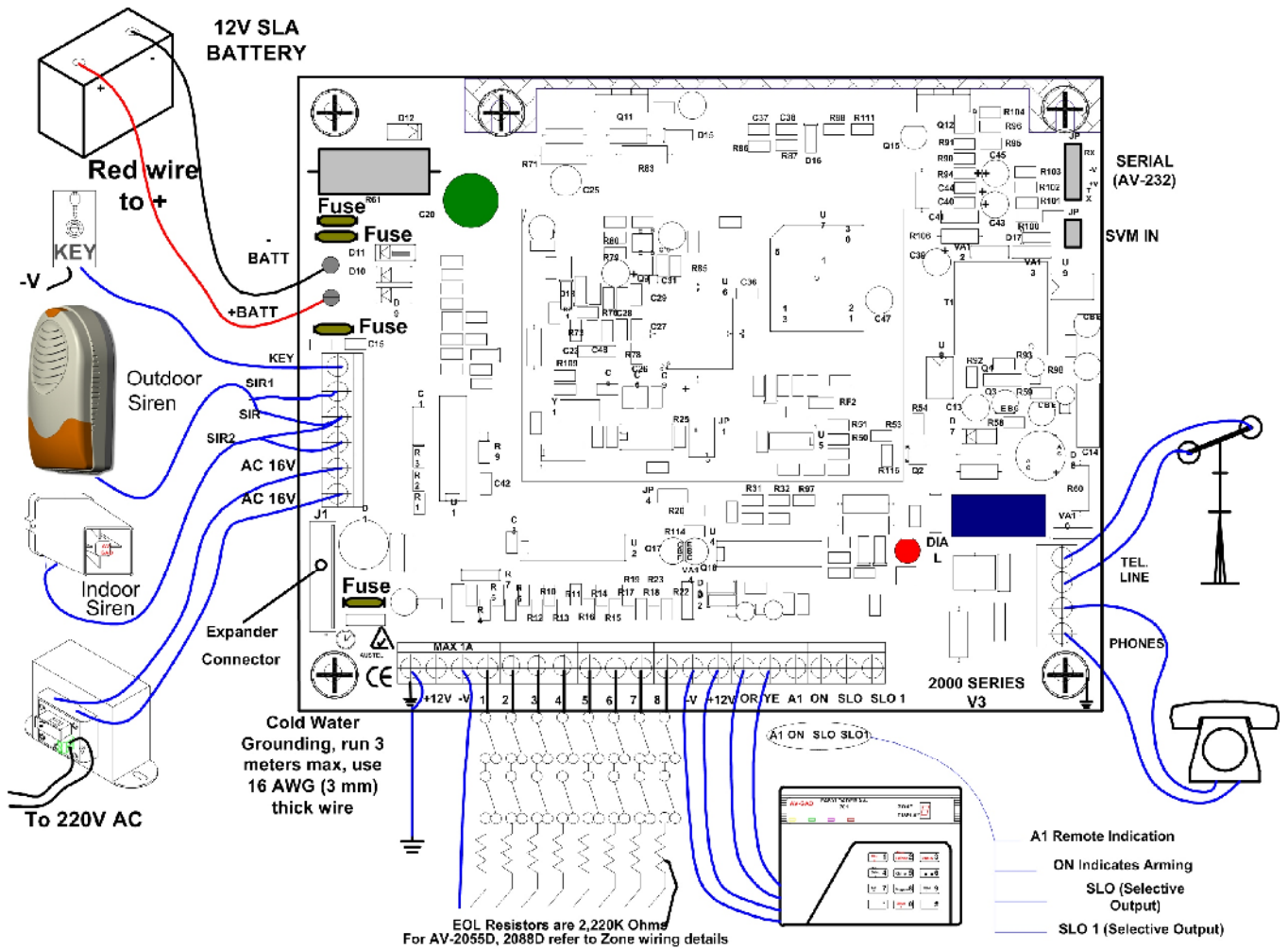

Figure 8: Wiring layout for AV-2055D & AV-2088D

WARNING:
To prevent electrical shock, disengage the System and disconnect the main & telephone line before servicing this unit.

SECTION V: WIRING DIAGRAM

Figure 9: AV-2016D and AV-2016DP Wiring Diagram

WARNING:
To prevent electrical shock, disengage the System and disconnect the Main & telephone line before servicing this unit.

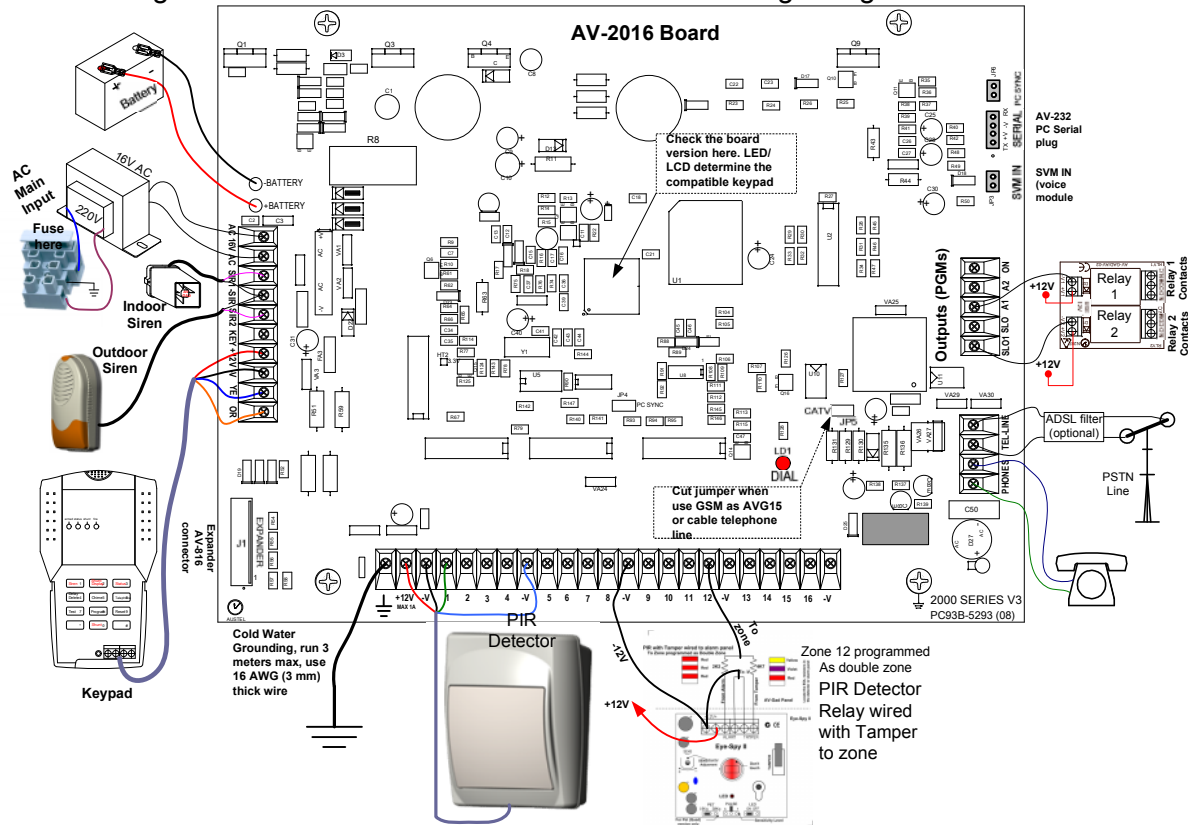

1• **Transformer:** Connect fused (0.5A) transformer to a non-switched main outlet.

Make sure to use fused main **not** connected to an automatic switch.

2• **Grounding:** Connect Ground from the board to Cold Water pipe (ground), using 2-2.5 m² wire, as short a length as possible, and no more than 4 meters.

3• **Fuses:** All fuses are Electronic type.

4• **Battery:** Non-replaceable type Fuse. Recommended Battery: Sealed Lead

Acid type 12V - 7.2 AH.

5• **EOL Resistors:** Use 2200 ohms (2K2) resistor.

6• **Keypad:** Connect maximum of four AV-701 or AV-706, 707 keypads.

7• **Remote Arming:** Use spring-return lock type; run wires of 20 meters maximum, or use wireless remote device to Arm/Disarm System.

8• **Sirens:** Connect horn-type siren (speaker) or 12V DC type (Bell). If using Bell adhere to maximum ratings (see Siren paragraph).

9• **Tel Line:** Dialing is applicable for DTMF and PULSE telephone systems.

SECTION VI: INDEX

A

Abort Report, 46
AC Power, 8
Address, 43
Answer Now, 26
Answering machine bypass, 46, 60
Arm and Disarm, 32
Arming - Upon all Delayed Clear, 47
Arming & Disarming Key and Wireless, 21
Arming Code, 34
Arming Denied, 32
Audible Test on Arming, 47
Auto Arming, 32
Auto Bypass, Disable, 46
AV-2016P LED Indicators, 68
AV-232, 62
AV-816 Connection, 12

B

Back-Up Battery, 18
Battery Charging, 8
Battery Test, 8
Bell Mode, 8
Bell Mode, Connection, 16
Buzzer, See Sounder, 29
Bypass Group, 48
Bypass Manual, 49
Bypass Via Code, 24, 49

C

Chime, 25
Code 8, Visitor Code, 34
Code No. 7 for Access Control, 34
Communicator Report-Central Station, 53
Contact ID, 55

D

Data Format, 53
Day Zone, 46
Default Programming Setting, 55
Default Programming Table, 43
Delay Delete, 25
Delayed Zone, 46
Dial Parameters, 46

Dialer, 8
Dialer Test, 25
Dialing, Default, 8
Digital Display, 31
Display Last 2 Users, 29
Door Chime, 25
Double-Pole Zone, 11
Downloading, 57
DTMF remote control, 21

E

End-User Code, 34
Entry Delays 1 and 2, 47
Events History, 27
Exit Delay, 47
Expander, 12
Extended Format, 53

F

Factory Default, 44
Fast Response, 48
Fault Find, 26
Fire Zone, 47
Follow Me Programming By User, 57
Follower Zone, 47
Follow-Me Erased Automatically, 47
Force Opening Code, 38
Fuses, 9

G

Green LED, 30
Grounding, 18
Group Bypass, 24
Group Bypass (Home Mode), 48

H

H, Zone H (Panic), 31
History Events-Detailed, 27
Hold-Down Function-Cancel, 29
Hold-Down Functions, 25
Housing, 8
Humidity, 8

I

Instant Arming, 48
Instant Zone, 46

K

Keypad Functions, 24
Keypad Keys Self Locking, 32
Keypad Mounting, 10
Keypad Wiring, 14

L

LEDs Flashing, 31

N

No EOL Resistor, 49
No Reset Zone, 48

O

Off Siren Time, 49
On Siren Time, 49
Opening/Closing Reporting, 54

P

Panic Button, 29
Pause, Dial Delay, 31
Power Failure, LEDs Indication, 31
Powering Up, 18
Program, Verify, 57
Programming Auto Dialer, 55
Programming Code, 34
Programming Code (Code 17), 49
Programming Examples, 51
Programming Quitting, 57
Programming Sheet, 36

R

Red Fire Led, 30
Red LED, 30
Re-Dial Cycles, 50
Relay Module, 17
Remote Momentary Key, 21
Report Bypassed Zones, 50
Reset Events Memory, 28
Reset for Smoke Detectors, 47
Reset Functions, 26
Resistor (EOL), 8

S

Shunt, 24
Shunt Display, 25
Single-Digit Format, 53
Siren Test, 25
Siren Test, upon Arming, 47
Smoke Detector Reset, 47
Sounder, 29
Sounder Response, 29
Specifications, 8
Status Display, 25
SVM Module, 50
SVM-40, 20
Swinger Shut-Down Zone, 50

T

Tamper Alarm-Lock in Arm, 48
Tampered Zones History, 28
Telephone Numbers, Delete, 57
Telephone System Dialing, 20
Temperature, 8
Test Signal to Central Station, 50
Testing Detection Devices, 26
Three lines, 32
Time Setting, 28
Troubleshooting List, 69
Twenty Four (24H) Hours Zone, 46
Two Digit Event Format, 54

U

Up and Download, 57

V

Value, 43

Y

Yellow LED, 30

Z

Zone Bypass Via Code, 24, 49
Zone In Use, 51
Zone Wiring Double-Pole Type, 11
Zone Wiring Mode, 10, 13
Zones Reset, 48

AV-GAD LIMITED WARRANTY

Av-Gad Systems Ltd. (Av-Gad) warrants its products to be free from production defects in components; materials used and labor for twelve months following the date of production. Av-Gad will within the mentioned period, as its option, repair or replace any product failing to proper operation without charging the purchaser.

WARRANTY

This warranty shall not apply to any equipment, or any part thereof, which has been repaired by others, installed not properly, used improperly, abused, altered damaged or subjected to forces of nature or on which the serial and data code is altered or removed.

Av-Gad will not be responsible for any dismantling or reinstallation expenses. In order to exercise the warranty, the purchaser must return the product; delivery and transportation costs will be prepaid and insured to Av-Gad.

After repair or replacement, Av-Gad assumes the cost of returning products under warranty.

There are no warranties, expressed or implied, which extend beyond the description of the face hereof.

There is no express or implied warranty of merchantability or a warranty of fitness for particular purpose. Additionally, this warranty is in lieu of all other obligations or liabilities on the part of Av-Gad.

Any action for breach of warranty, including but not limited to any implied warranty of merchantability, must be brought within three months following the end of the warranty period. In no case shall Av-Gad be liable to anyone for any consequential or incidental damages for breach of this or any other warranty, expressed or implied, even if the loss or damage is caused by the seller's own negligence or fault.

Av-Gad is not an insurer of either the property or safety of the user's employees, family, or 3rd part and limits its liability for any loss or damage including incidental or consequential damages to Av-Gad original selling price of the product regardless of the cause of such a loss or damage.

Av-Gad hereby declares that service, technical support and spare parts will be supplied for 60 months following the date of production. Price list for such services to be update from time to time.