

# **AVX-300**

## **Outdoor PIR + MW detector with Double Dual Mirror Optics**

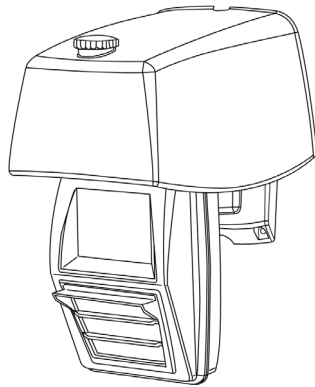

### **INSTALLATION INSTRUCTIONS & USER MANUAL**

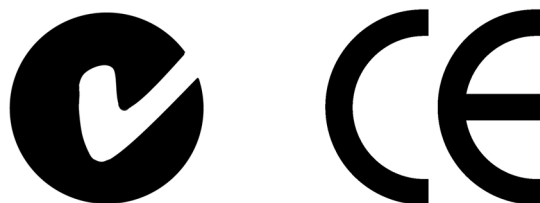

The AVX-300 is unique PIR and Microwave detector for outdoor and harsh environment applications.

It comprises of Double Mirror Optics and advanced MW Detector inside stylist rigid plastic body. This special mirror optics combined with state of the art MW Doppler sensor assures elimination of “false alarms” while maintaining high security standards for the detection of human intruders into protected area.

The detection sensitivity and range is controlled by digital rotary switch allowing 16 calibration levels, so that the effective pattern will be set for every installation environment and protection site.

The AVX-300 is designed to protect large areas and can easily be installed on walls in order to provide a solid protection of the area while rejects interferences from birds and small animals due to “PET MASK” optics.

The AVX-300 is designed for continuous round-the-clock operation and keeps its performances within a wide temperature and humidity range.

AVX-300



### **AVX-300 FEATURES**

- Double Dual PYRO sensor.
- Full pattern double mirror optics.
- MW detection based on Doppler concept.
- FET based DRO with strip line antenna.
- VLSI based electronics with movement speed spectrum analysis.
- N.O. & N. C. Relays switched at the same time.
- Height installation calibrations free, from 1.5m to 3.0m
- Pet and small animal Immunity up 40kg.
- 16 levels of MW and PIR sensitivity adjustment.
- Environmental immunity.
- Temperature compensation.
- Micro controller signal processing.
- Tamper protection.
- Sound indication for walk test and intruder detection.
- Unique waterproof and seal plastic design.
- Detection Range: Up to 40m (with LR Mirrors)
- Detect human intruders walking or running.
- No maintenance required.
- High RFI/EMI Immunity.
- Protection from: direct sunlight, wind up to 30 m/sec, snow and rain, small Pet animals, removing the top cover, housing pulling out or destruction.

### **Selecting mounting location**

The installation of the AVX-300 requires straight and solid base for the detector and setting of front panel against the center of protected area.

Local conditions of the protected zone must be free from obstacles like walls, fences, trees, ditches and other microwave detectors and systems of anti-intrusion surveillance.

The bracket provides AVX-300 installation on the wall, allowing changing the installation angle (vertically and horizontally) in wide range (FIG.2).

The wall should be leveled with a maximum slope angle of 10°.

Choose a location most likely to intercept an intruder according to detection pattern in FIG.: 6.

### Avoid the following Installation Locations:

- Facing direct sunlight.
- Facing areas subject to rapid temperature changes.
- Wall angle of more than 10° from perpendicular line.
- Mounting at more than 10° Deviation from horizontal line.
- Facing metal doors.
- Avoid installation of AVX-300 on the following types of ground: Thick vegetation, Grass (un-mown), Water, Sand and Metal. Install the AVX-300 on stable and moving-free objects.

### NOTE:

Recommended installation height is 2.4 meter.

The Double Dual high quality sensor detects motion crossing the beam; it is less sensitive detecting motion towards the detector.

The AVX-300 performs best when provided with a constant and stable environment.

In order to ensure suitable operation of the AVX-300 type of ground should be one of the following: Asphalt, Cement, Soil, Clay, Gravel or Grass (mown).

### Mounting the detector

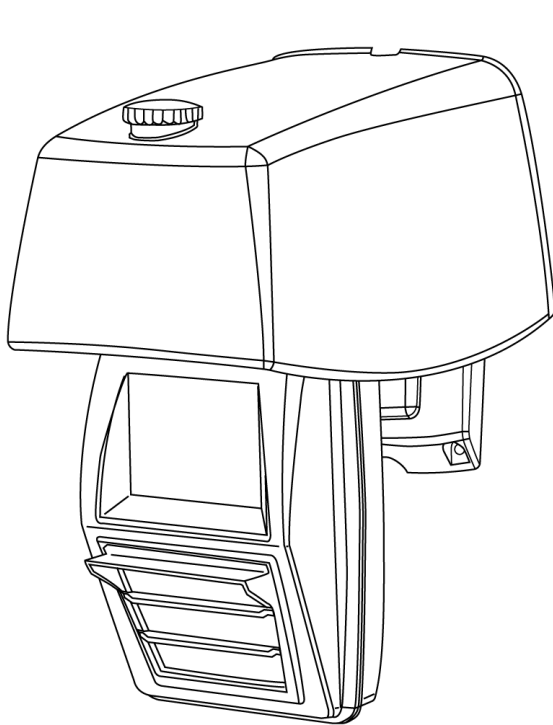

Fig.1 Cover opening

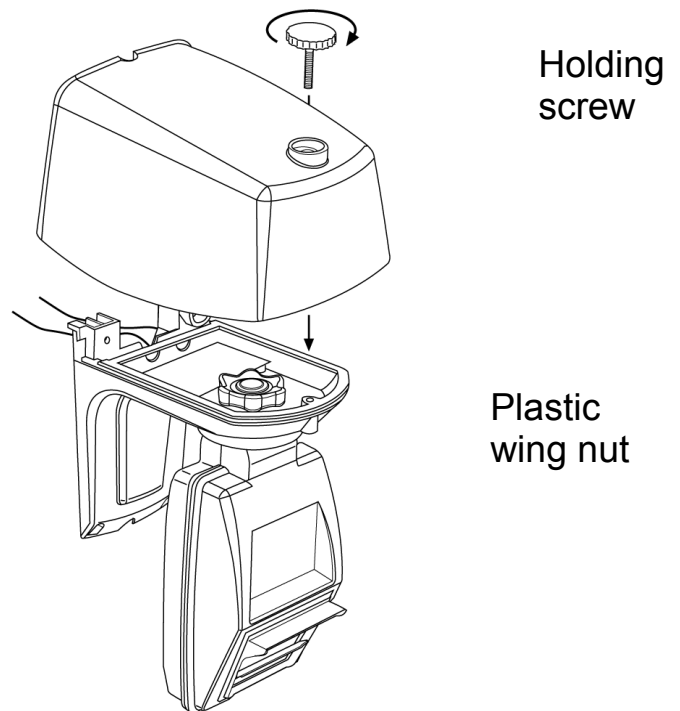

Fig.2 Wiring and positioning

Use the AVX-300 back bracket for wall installation.

Remove top cover by unscrewing the holding screw at the topside of the bracket.

Attach bracket to the wall using 4 screws and anchors (See fig. 1).

Insert the wire through the “line/hole wire bracket” under silicon gasket (See fig. 2).

Access for wiring connections is easy via the terminal block located on the PCB. See fig. 3.

For detector alignment, unscrew the plastic wing nut, adjust the detector facing against the center of protected area and tighten the nut.

Replace the detector top cover.

Screw the holding screw.

## TERMINAL BLOCK CONNECTIONS

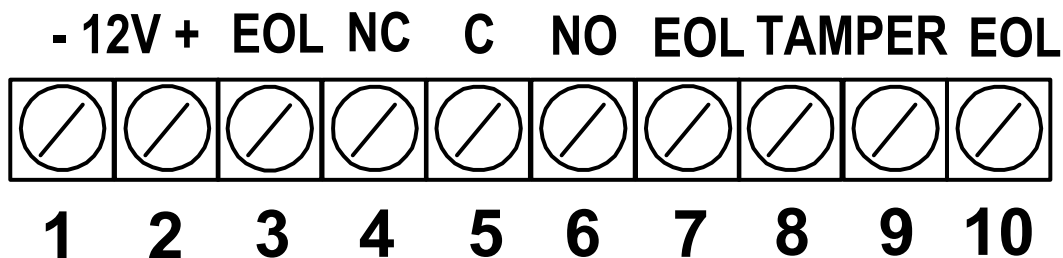

Fig.3. Wiring connections

**Terminal 1 – Marked “ - ” (GND)** – Connect to the ground of the control panel.

**Terminal 2 – Marked “ + ” (+12V)** – Connect to a positive Voltage of 8.2 –16Vdc source (usually from the alarm control unit)

**Terminals 4, 5 & 6 – Marked “ NC C NO ”** - These are the output relay contacts of the detector. Connect to a normally closed or normally opened zone in the control unit. When an intruder is detected, alarm relays (N.O. and N.C.) will switch for 1.8 sec.

**Terminals 8 & 9 – Marked “Tamper”** – If a Tamper function is required connect these Terminals to a 24-hour normally closed protective zone in the control unit.

If the top cover of the detector is opened or the detector is detached from installation wall, an immediate alarm signal will be sent to the control unit.

**Terminals 3, 7 & 10 – Marked “ EOL ”** - End of line – optional terminals for end of line resistors connections.

### **WIRE SIZE REQUIREMENTS**

Use #22 AWG or larger wires. Use the following table to determine required wire gauge and length.

Wire Gauge:	#	22	20	18	16
Wire Length:	m	205	310	510	870
	Ft.	800	1200	2000	3400

## TOP PCB LAYOUT

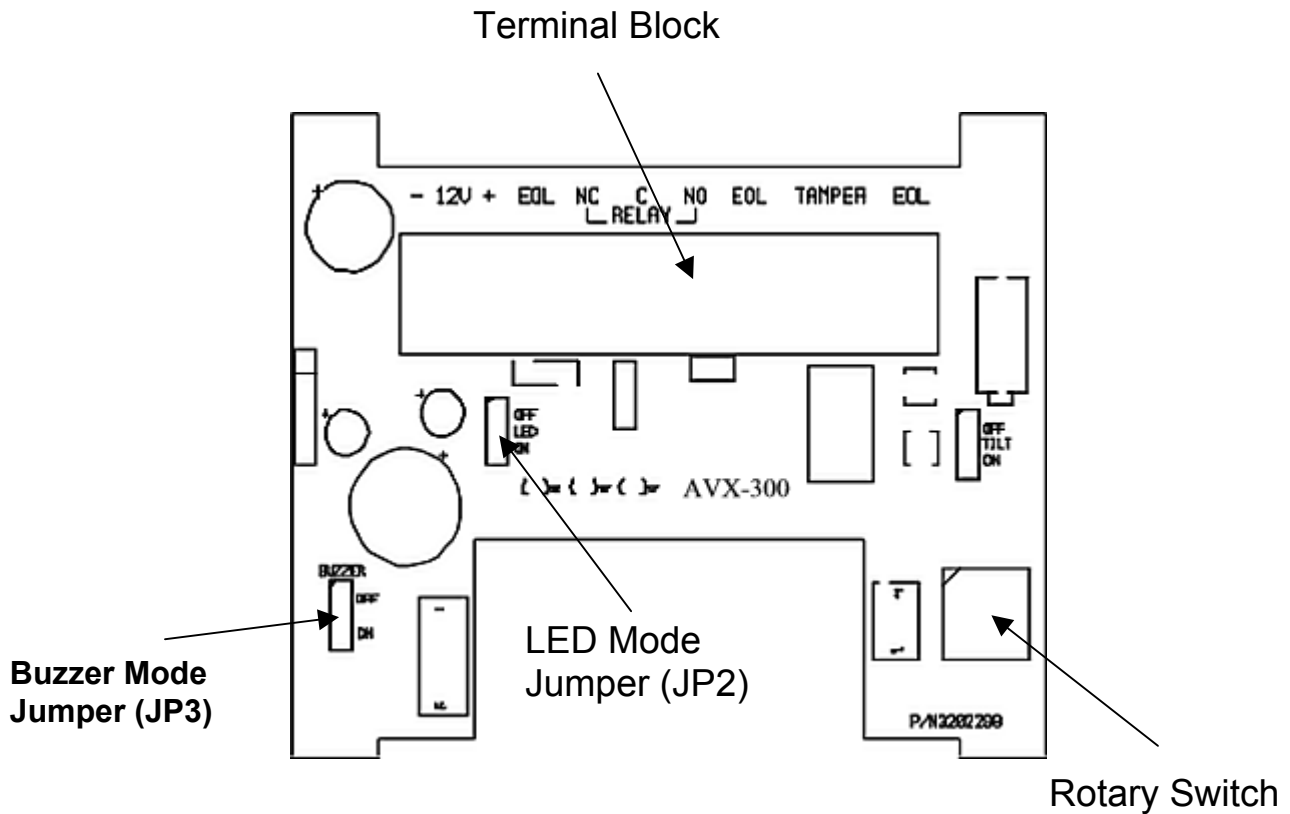

Fig.4 Interface PCB layout

### **LED INDICATORS**

- YELLOW LED - MW detection, is blinking during warm up period and self testing
- GREEN LED - PIR detection
- RED LED - Alarm

### **Test and Tuning**

#### **Sensitivity And Range Adjustment**

The calibration of range and sensitivity is performed by single digital 16 position rotary switch. There are 3 groups of switch setting according to detection range. Each group is divided to several levels of sensitivity according to installation environment. The sensitivity levels values changed upon the mirror optic type.  
WA = wide angle. LR = Long range

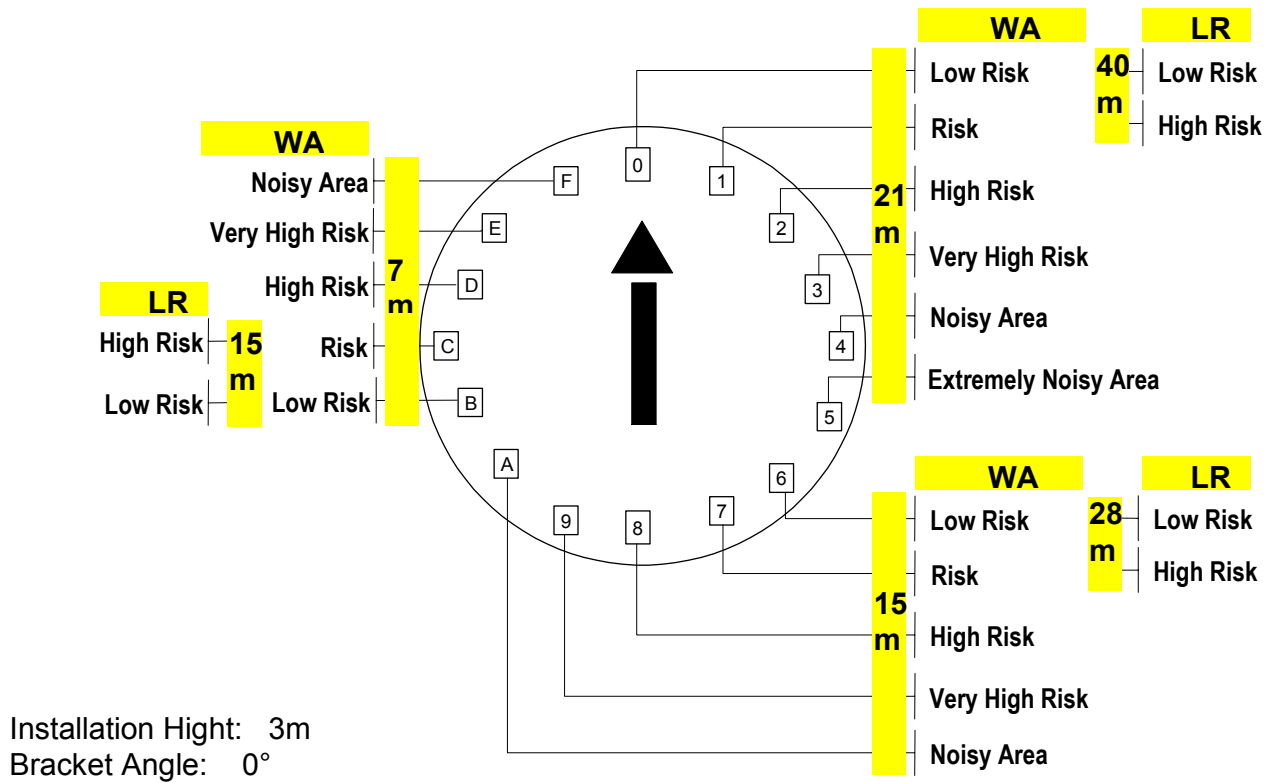

Fig. 5 Rotary switch setting

**For WA (Wide Angle) mirror optic**

The WA version is covering 18 meters range and 90° at temperature of 21° C. As the temperature rise the sensitivity is decreasing.

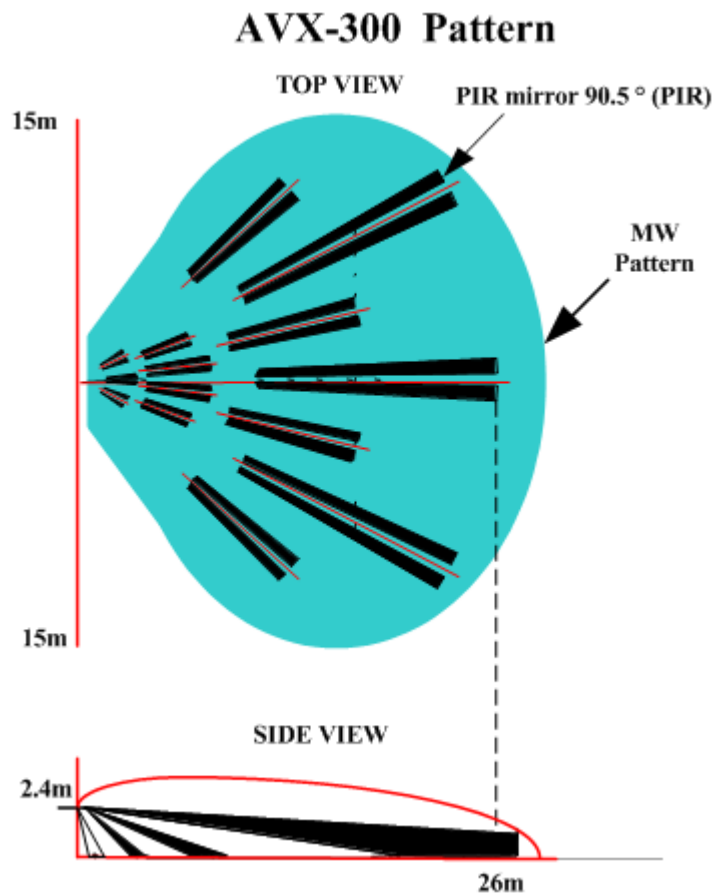

Fig.6 Wide Angel (WA) PIR + MW Detection Pattern

## For LR (Long Range) mirror optic (optional Model AVX-300-LR)

For long range optics order item AVX-300-LR.

Group A - positions 0 and 1 – set sensitivity for 40m detection range

Group B - positions 6 and 7 – set sensitivity for 28m detection range

Group C - positions B and C – set sensitivity for 15m detection range

Each range group includes 5 or 6 setting levels according to environmental condition risk.

Example: If detector is used for 15m range with sunlight, set switch to position 8 or 9.

## Jumpers Setting

### LED Mode Jumper (JP2)

Connect a jumper between the marked terminals to enable or disable the LED (ON or OFF).

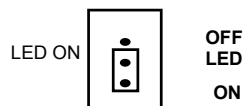
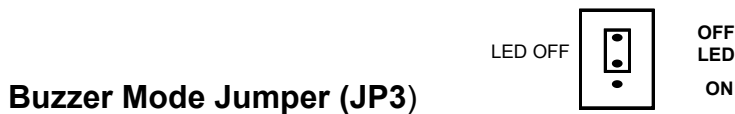

Buzzer provides the sound indication of Alarm signal.

If a buzzer function is required, connect a jumper in position ON, if it is not required – in position OFF.

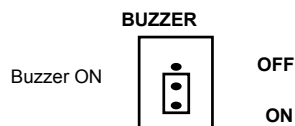
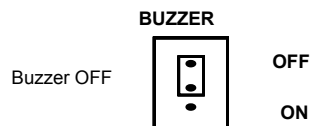

The buzzer function is useful during walk test when it is hard to see the LED.

**Important: You must reset the detector from Control Panel or by powering down than powering up, before the new settings will take effect**

## Test procedure

### Walk Test

After tuning the sensitivity, connect 12Vdc power to the system.

Allow 2 minutes of warm up time.

Make sure that the protected area is cleared of all people.

1. Start walking across the detection zone.
2. Listen to ALARM sound whenever motion is detected (The red LED turns on also whenever motion is detected).
3. Allow 5 sec. between each test for the detector to stabilize.

**NOTE:** Walk Test procedure should be conducted, at least once a week, to confirm proper operation and coverage of the detector.

## Specifications

Detection Method	Double Dual element PIR & MW
Wide Range Mirror Pattern	90.5° with 30 zones detection
Microwave Frequency	X-Band: 9.9 GHz 10.525 GHz 10.687 GHz S-Band: 2.45 GHz
Scope (Length of protection zone)	Max. 21m (WA mirror) max 10. 40m (LR mirror)
Power Supply Voltage	8.2 to 16 V filtered DC
Current consumption	Start-up: 28mA ± 3mA Standby: 23mA ± 3mA Active: 20mA ± 3mA
Relay contacts values	N.C 28Vdc 0.1 A with 10 Ohm protection resistors N.O 28Vdc 0.1 A with 10 Ohm protection resistors
Warm up Period	120 Sec (Max.)
Alarm Period	1.8 Sec (Max.)
Tamper Switch	N.C 28 Vdc Maximum current 0.1 A - open when cover is removed
Detection Speed (Target velocity)	0.3 to 3 m/sec
Dimensions of unit with bracket	192mm x 153mm x 251mm
Gross Weight	0.57 Kg
Operating temperature range	-20°C ~ +60°C
Weatherproofing	<ul style="list-style-type: none"> <li>• All openings with gasket and sealed</li> <li>• Protection against water and dust</li> </ul>
RFI Protection	30V/m 10 – 1000 MHz
EMI Protection	50,000V of electrical interference from lightning or power through
Visible Light Protection	Stable against halogen light, sunlight or reflecting light

Warranty is according to Av-Gad “Detectors and Sensors Warranty” terms and manual.

\* Specifications are subject to change without prior notice.